

## SETUP SHEET for the Team Associated RC10T4

Driver \_\_\_\_\_

Track / City \_\_\_\_\_

Event \_\_\_\_\_ Date \_\_\_\_\_

### FRONT

SHOCK MOUNTING & CAMBER LINK

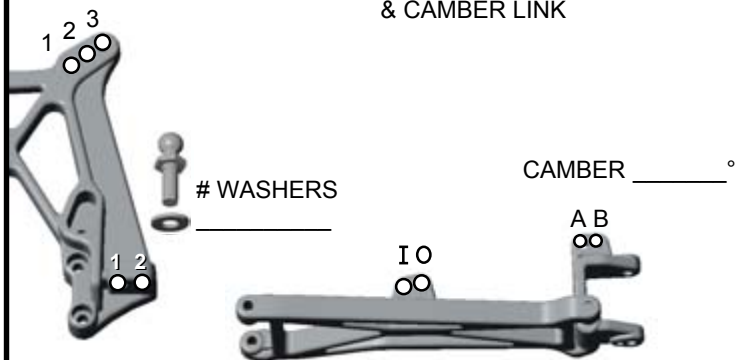

RIDE HEIGHT \_\_\_\_\_

TOE-IN (+) / OUT (-) \_\_\_\_\_°

BUMP STEER SPACER \_\_\_\_\_

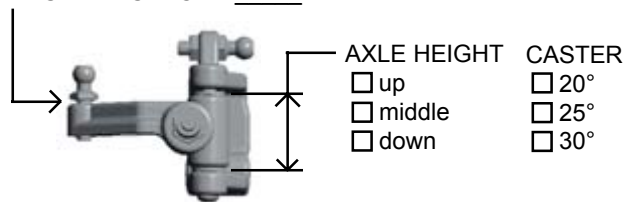

STEERING BLOCK  trailing  inline

### FRONT SHOCKS

OIL \_\_\_\_\_ wt

SPRING (color) \_\_\_\_\_ PISTON # \_\_\_\_\_

SHAFT  unobtainium  STD # LIMITERS \_\_\_\_\_

### FRONT TIRES & WHEELS

FRONT TIRES \_\_\_\_\_

INSERTS \_\_\_\_\_ WHEELS \_\_\_\_\_

TRACTION COMPOUND \_\_\_\_\_

### REAR

SHOCK MOUNTING & CAMBER LINK

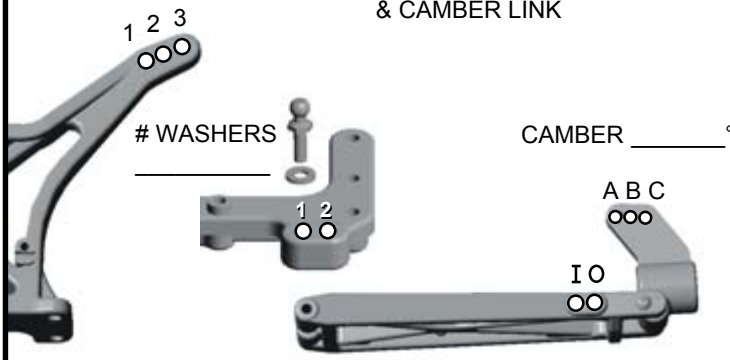

RIDE HEIGHT \_\_\_\_\_

ANTI-SQUAT

- 0°
- 1°
- 2°
- 3°

WHEELBASE

- long
- medium
- short

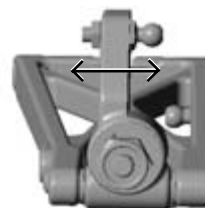

ANTI-ROLL BAR

- none
- black (soft)
- silver (med)
- gold (heavy)

### REAR SHOCKS

OIL \_\_\_\_\_ wt

SPRING (color) \_\_\_\_\_ PISTON # \_\_\_\_\_

SHAFT  unobtainium  STD # LIMITERS \_\_\_\_\_

### REAR TIRES & WHEELS

REAR TIRES \_\_\_\_\_

INSERTS \_\_\_\_\_ WHEELS \_\_\_\_\_

### RADIO/BATTERIES

RADIO \_\_\_\_\_ SERVO \_\_\_\_\_

ESC \_\_\_\_\_

DRAG BRAKE \_\_\_\_\_ INIT BRAKE \_\_\_\_\_

BATTERIES \_\_\_\_\_

BATTERY PLACEMENT: spacers in front \_\_\_\_\_ spacers in rear \_\_\_\_\_

### MOTOR

MOTOR & WIND \_\_\_\_\_

BRUSHES \_\_\_\_\_

SPRING \_\_\_\_\_

PINION / SPUR \_\_\_\_\_ / \_\_\_\_\_

### OTHER

BODY \_\_\_\_\_

SPOILER \_\_\_\_\_

CHASSIS \_\_\_\_\_

### CONDITIONS

- smooth
- bumpy
- low traction
- med traction
- high traction
- sandy
- soft dirt
- grass
- blue groove
- clay
- wet
- dry
- dusty
- other

### COMMENTS