

1:10 Scale 2WD Electric Off Road Competition Truck Kit

RC10T
FACTORY TEAM

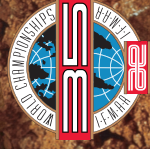

TEAM ASSOCIATED



1:10 Scale 2WD Electric Off Road Competition Truck Kit Manual

#7004 RC10T Factory Team Truck Kit



CHAMPIONS *by* **DESIGN**

AssociatedElectronics.com

TEAM ASSOCIATED

⚙️ Introduction

Thank you for purchasing this Team Associated product. This assembly manual contains instructions and tips for building and maintaining your new vehicle. Please take a moment to read through the manual and familiarize yourself with the steps. We are continually changing and improving our designs; therefore, actual parts may appear slightly different than the illustrations. New parts will be noted on supplementary sheets located in the appropriate parts bags.

Check each bag for these sheets before you start to build.

Check www.AssociatedElectrics.com for the latest versions of our instruction manuals.

⚙️ RC10T FT Kit Features

- New Factory Team carbon fiber front shock tower (big bore compliant)
- New Factory Team carbon fiber rear shock tower (big bore compliant)
- New Factory Team 12mm hex front steering block
- New Factory Team 12mm hex front axle
- Factory Team 12mm Hex rear CVA's included
- 12mm Hex T7 wheels included
- B7 Servo mount included
- Heavy Duty Metric Ball Studs
- Carbon fiber transmission brace
- Heavy Duty Ball Cups and 3.5mm adjustable turnbuckles
- New Factory Team captured hinge pins all around
- Kashima coated 13mm big bore factory team shocks included
- All Black plastics
- Full ball bearings included
- Bronze color anodized chassis, noseplate and motorplate
- New Factory Team RC10T logo decal sheet
- V2 slipper system included
- RC10 T2 suspension arms included

⚙️ Additional

Your new kit comes unassembled and requires the following items for completion (refer to www.AssociatedElectrics.com and www.Reedypower.com for suggestions):

- R/C two channel surface frequency radio system
- AA-size batteries for transmitter
- Electronic Speed Control ("ESC")
- Steering servo
- R/C electric motor (540 size)
- Pinion gear (48P), size determined by type/turn or kV of motor
- Battery charger (a peak detection charger, or LiPo compatible charger)
- 2 cell LiPo battery pack
- Polycarbonate specific spray paint
- Cyanoacrylate glue ("CA") (#1697)
- Thread locking compound (#1596)
- Tires and Inserts, Fronts and Rears

⚙️ Other Helpful Items

- Silicone Shock Fluid (Refer to AssociatedElectrics.com for complete listings)
- Green Slime shock lube (#1105)
- FT Turnbuckle Wrench, 4mm (#1112)
- FT Body Reamer (#1499)
- Shock Pliers (#1681)
- Wire Cutters
- FT Hex/Nut Wrenches 11/32" (#1519)
- FT Ballcup Wrench (#1579)
- Hobby Knife
- Needle Nose Pliers
- FT Universal Tire Balancer (#1498)
- Calipers or a Precision Ruler
- FT Body Scissors (#1737)
- Soldering Iron

Associated Electrics, Inc.
21062 Bake Parkway
Lake Forest, CA 92630



Customer Service
Tel: 949.544.7500
Fax: 949.544.7501

Hardware - 1:1 Scale View

Cap Head (shcs)

	4-40 x 1/4" (6649)
	4-40 x 5/16" (6649)
	4-40 x 3/8"
	4-40 x 1/2" (6649)
	4-40 x 5/8" (6926)
	4-40 x 3/4" (6649)
	4-40 x 1"
	1.6 x 5mm (91611)

Flat Head (fhcs)

	4-40 x 3/8" (6316)
	4-40 x 1/2" (6538)
	8-32 x 1/4" (6931)
	8-32 x 1/2" (6316)
	8-32 x 7/8" (6316)

Button Head (bhcs)

	0-80 x 3/16"
	4-40 x .125"
	4-40 x 3/16"
	4-40 x 1/4"
	4-40 x 5/16"
	4-40 x 3/8"
	4-40 x 1/2"
	2 x 4mm (31510)
	3 x 6mm (31531)
	3 x 22mm (25189)

Shims and Washers

	Dogbone spacer
	.030 Nylon Spacer (4187)
#4 Washer"/>	#4 Washer
	1/4" Axle Shim
	Diff Thrust Washers
	5mm x 9.5mm 0.17mm
#8 Aluminum Thick Washer"/>	#8 Aluminum Thick Washer

Nuts (lock/plain)

	4-40 Small Pattern Plain Nut
	4-40 Nuts
	5-40 Locknut
	8-32 Steel Locknut
	M2 Locknut (21689)
	M3 Nut (91477)
	M3 Alum. Locknut, Blue (31550)
	M3 Locknut, Black (25215)

Ball Bearings

	5/32 x 5/16 x 1/8" (6589)
	3/16 x 3/8 x 1/8" (3977)
	FT 3/16 x 3/8 x 1/8" (6906)
	3/16 x 5/16 x 1/8" (6909)
	3/8 x 5/8 x 5/32" (3976)

Set Screws

	4-40 x 3/32" (6907)
	4-40 x 1/8"
	4-40 x 5/16"

Diff Balls

	3/32 Diff Balls
--	-----------------

LP Socket Head (shcs)

	3x8mm (41096)
--	---------------

Notes:

Ballstuds

	HD 4mm, Short (32041)
	HD 6mm, Short (32042)
	HD 8mm, Short (32040)
	HD 4mm (91451)
	HD 6mm (91047)
	Ti HD 6mm (91751)
	HD 8mm (91048)
	Ti HD 8mm (91752)

Table of Contents

1.....	Cover	10.....	Turnbuckles Build (Bag F)
2.....	Introduction	12.....	Shocks Build (Bag G)
3.....	1:1 Hardware “Fold Out”	14.....	Transmission Build (Bag H)
4.....	Table of Contents	17.....	Wheels / Tires Build (Bag I)
5.....	Nose Plate / Steering Build (Bag A)	19.....	Painting Tips and Notes
6.....	Servo saver Build (Bag B)	20.....	Vegas 2025 Setup Sheet
7.....	Front Bumper / Body Mount Build (Bag C)	21.....	Blank Setup Sheet
7.....	Servo Mount Build (Bag D/F)	22.....	Back Cover
8.....	Rear Suspension Build (Bag E)		

Notes



This symbol indicates a special note or instruction in the manual.



This symbol indicates the number of the same part that is required.



This symbol indicates the order within a step to assemble parts.



This symbol indicates there are optional FT parts available



This symbol indicates a Racers Tip.



This symbol indicates where Thread Lock Adhesive should be applied. *not included

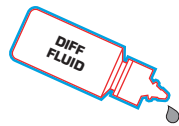

This symbol indicates where Diff Fluid should be applied.

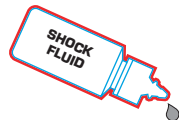

This symbol indicates where Shock Fluid should be applied.



This symbol indicates where FT Silicone Grease should be applied. *not included



This symbol indicates where FT Diff Lube should be applied. *not included



This symbol indicates where Black Grease should be applied.



This symbol indicates where Green Slime can be applied. *not included



There is a 1:1 hardware foldout page in the front of the manual. To check the size of a part, line up your hardware with the correct drawing until you find the exact size. Each part in the foldout has a number assigned to it for ordering replacement parts.

:: Nose Plate / Steering Build - Bag A - Step 4

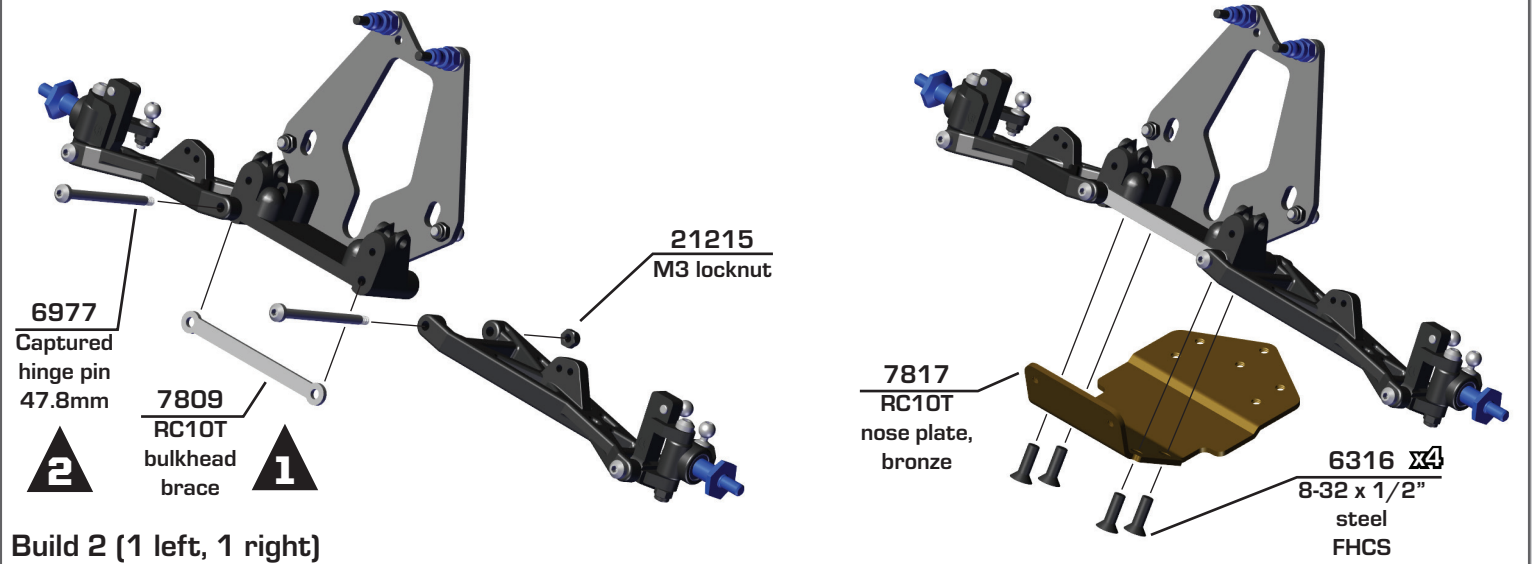

:: Nose Plate / Steering Build - Bag A - Step 5

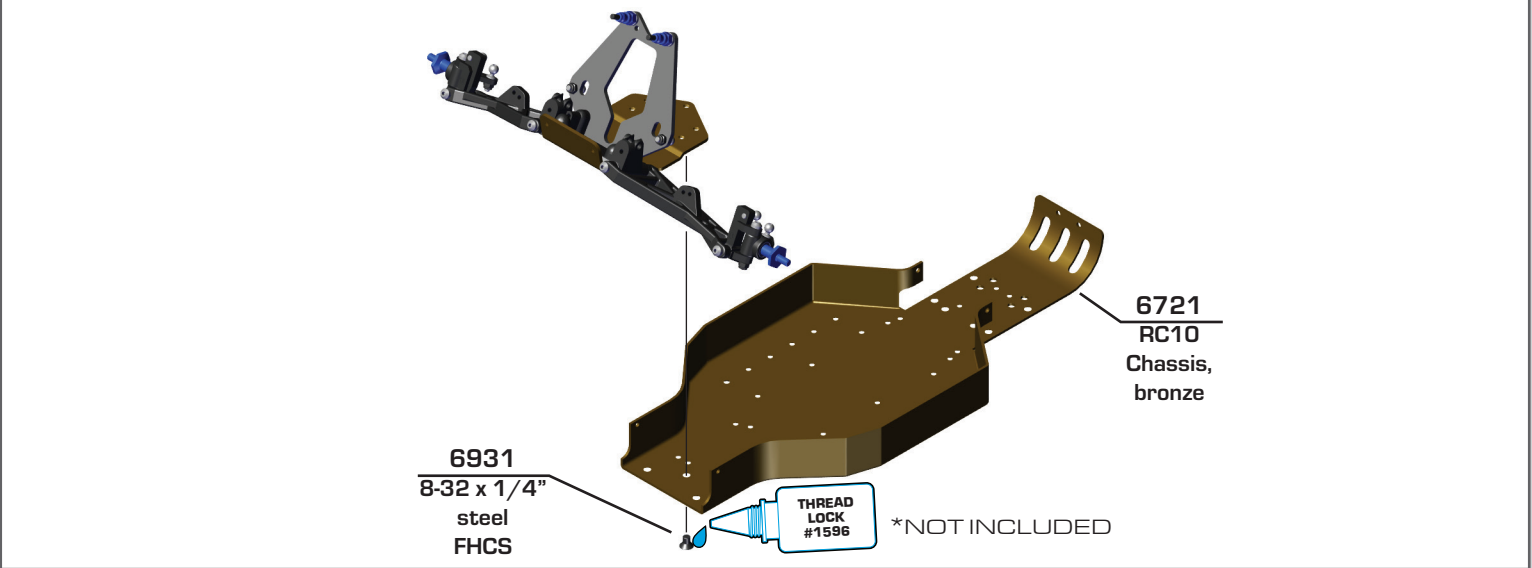

:: Servo Saver Build - Bag B - Step 1

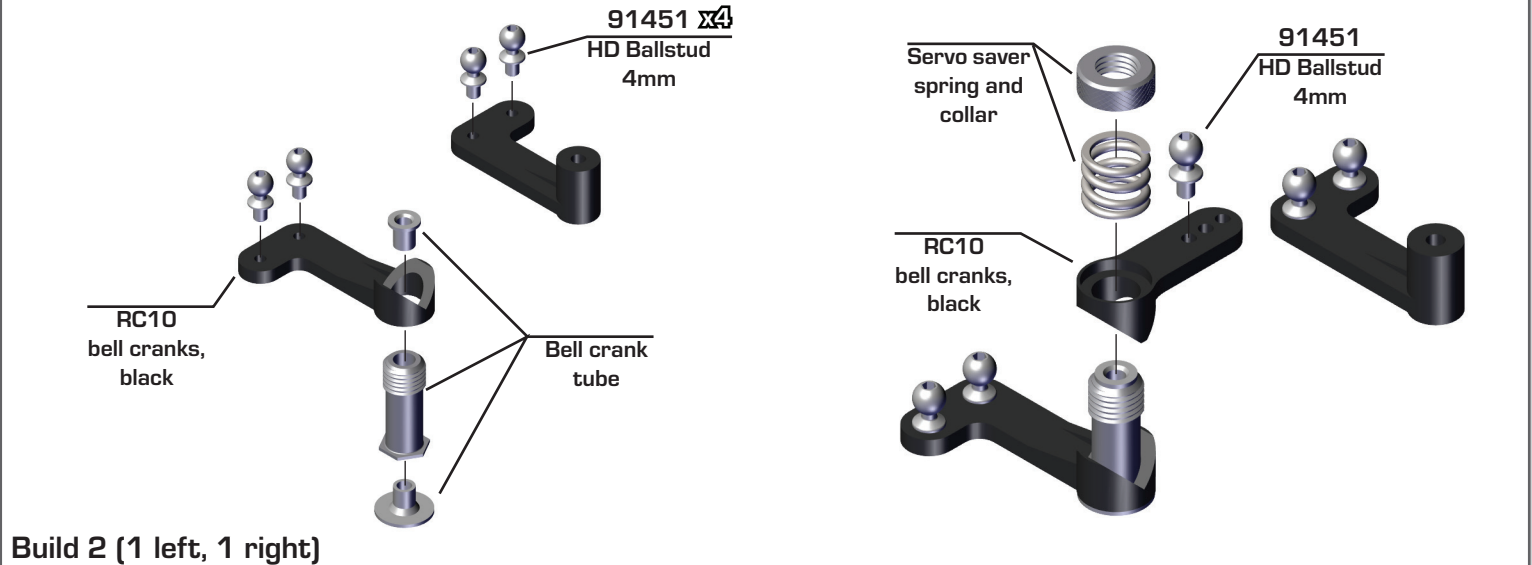

:: Servo Saver Build - Bag B - Step 2

x2
4-40 locknut

x2
3x7x0.5mm washer

! Tighten 4-40 nuts until snug & bellcrank rotates freely!

OPTIONAL
6638
RC10 nose brace tubes, silver

x2
RC10 nose brace tubes, black (kit exclusive color)

x2
4-40 x 5/16" SHCS

x2
4-40 x 1/2" SHCS

7306 Servo saver screw, long

7306 Servo saver screw, short

THREAD LOCK #1596

:: Front Bumper and Body Mounts - Bag C - Step 1

7814 Front body mount brace, black

7814 **x2** Front body mounts

x2 4-40 x 3/8" SHCS

x2 4-40 x 1/2" BHCS

x2 4-40 nut

x2 4-40 x 3/8" FHCS

7814 RC10GT front bumper, black

:: Servo Mount Build - Bag D/F - Step 1

Servo not included!

92418 B7 servo mount

41096 **x4** 3x8mm LP SHCS

BLACK GREASE #6588

92308 **x2** HD Ball cups

6547 Steel turnbuckle, Silver (3.5x48mm)

!

Servo Turnbuckle 1.18" (30mm)

Racers Tip:
Use black grease (#6588) on the threads of the turnbuckles for easier ball cup installation!

Orient the notch to the left throughout the car. It indicates which end has the left hand threads!

⚡ Servo Mount Build - Bag D - Step 2

32041
HD ball stud,
short, 4mm

Servo
horn and
screw not
included!

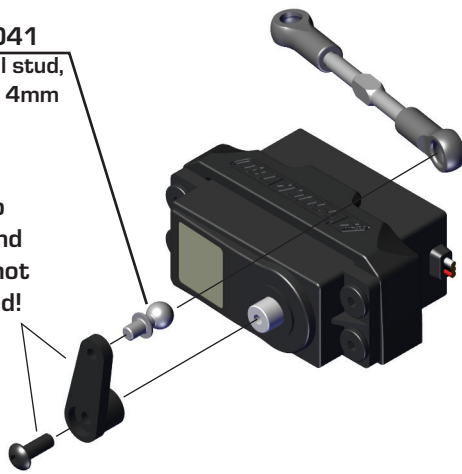

6649 x2
4-40 x 3/8"
FHCS

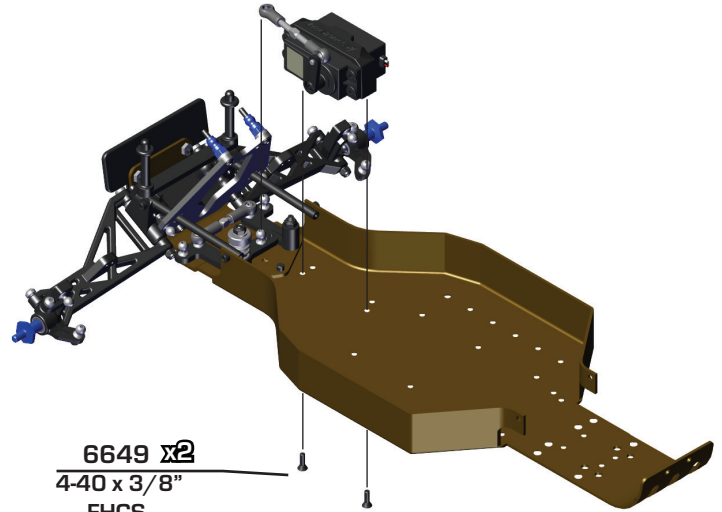

⚡ Servo Mount Build - Bag D - Step 3

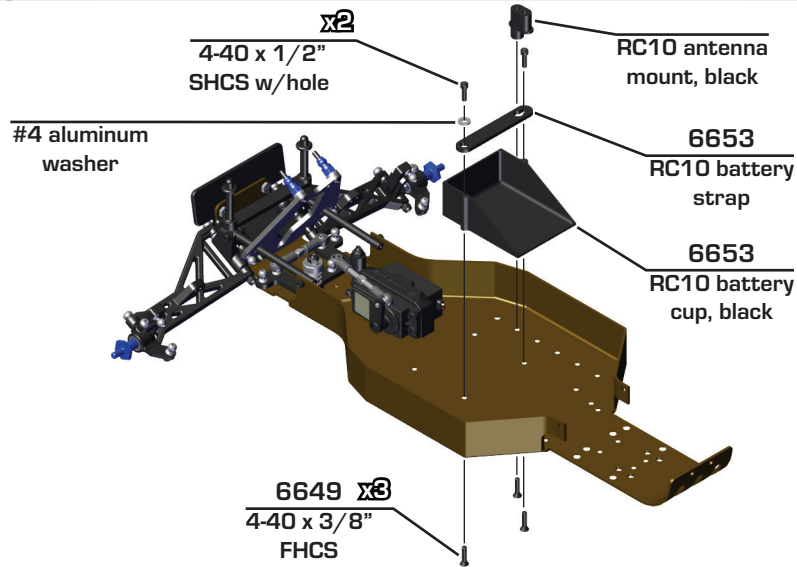

⚡ Rear Suspension Build - Bag E - Step 1

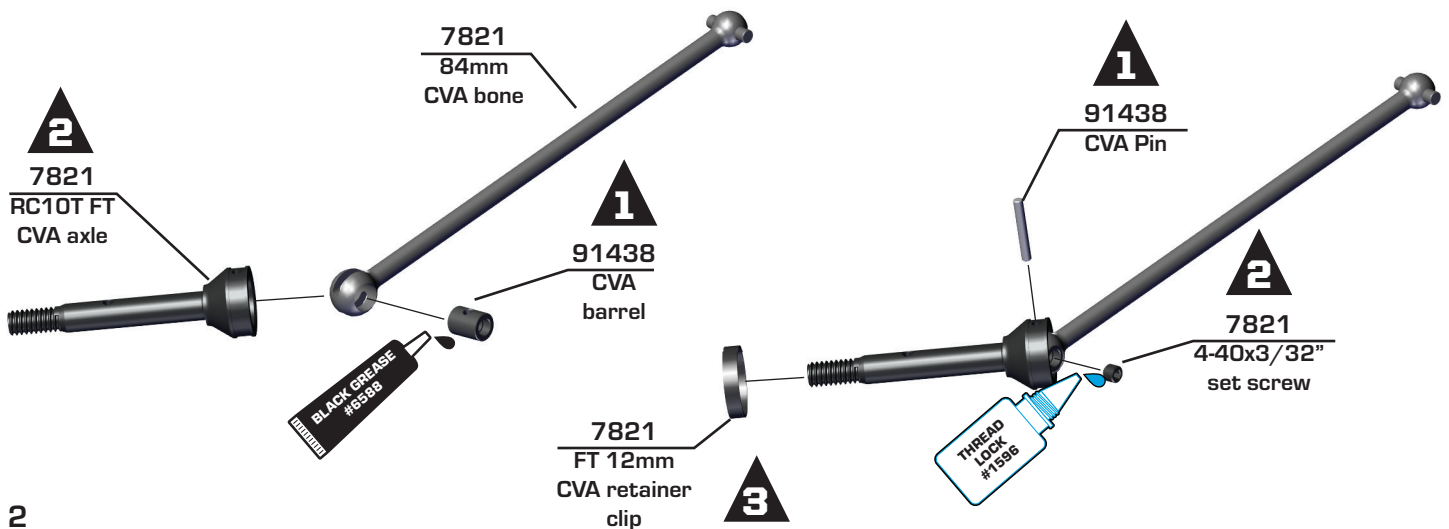

:: Rear Suspension Build - Bag E - Step 2



:: Rear Suspension Build - Bag E - Step 3

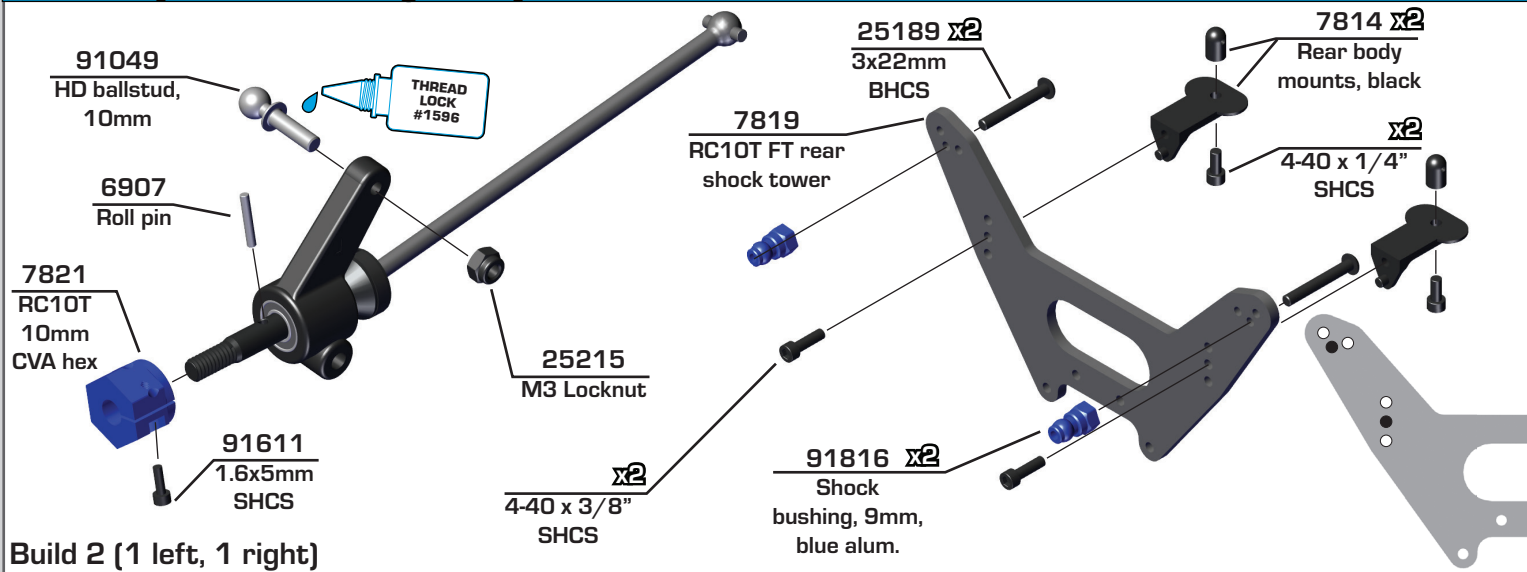

:: Rear Suspension Build - Bag E - Step 4

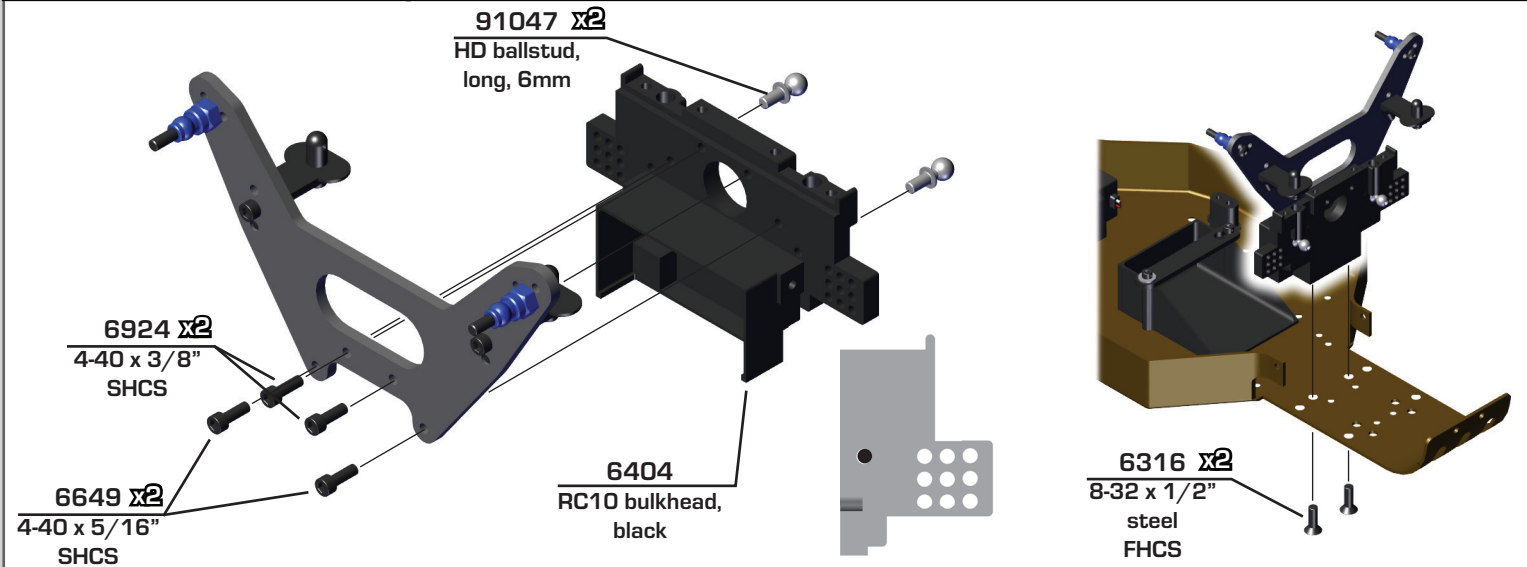

⚡ Rear Suspension Build - Bag E - Step 5

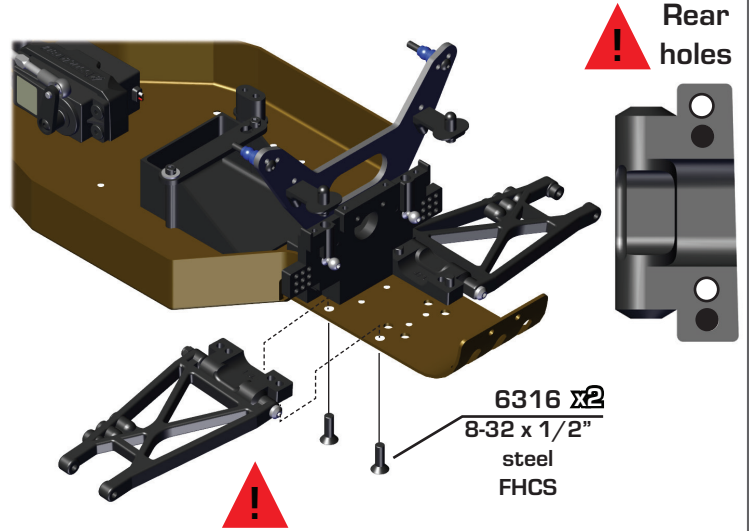
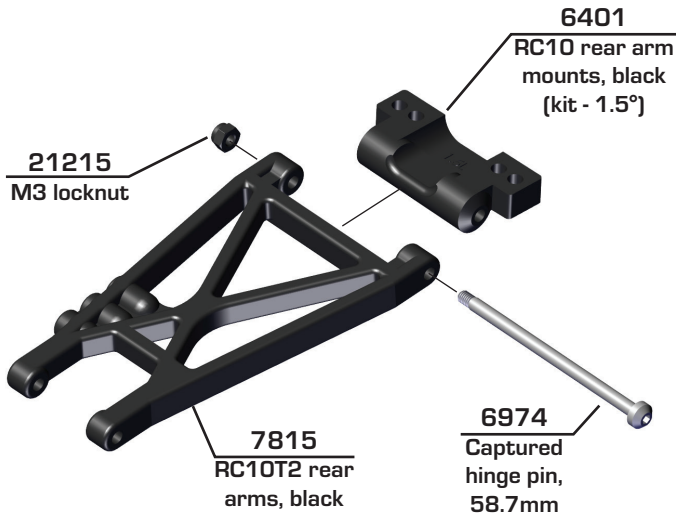

Build 2 (1 left, 1 right)

⚡ Rear Suspension Build - Bag E - Step 6

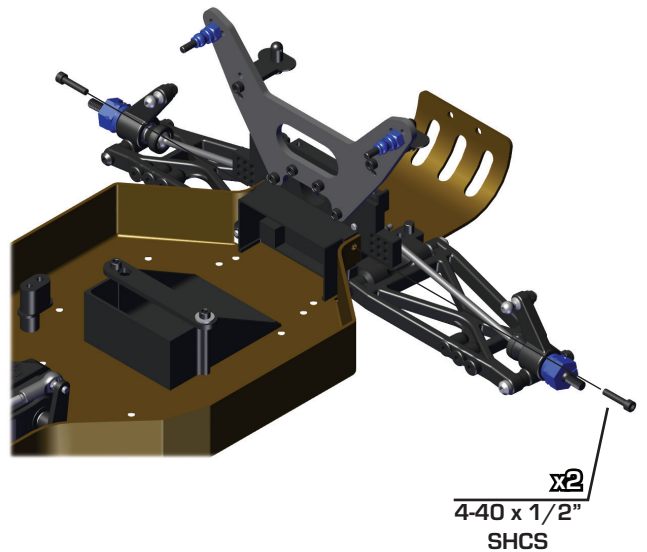
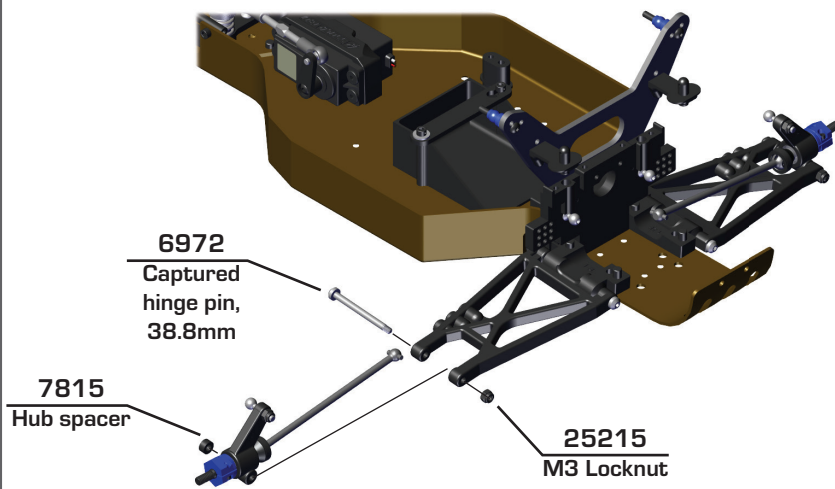

Build 2 (1 left, 1 right)

⚡ Turnbuckles Build - Bag F - Step 1

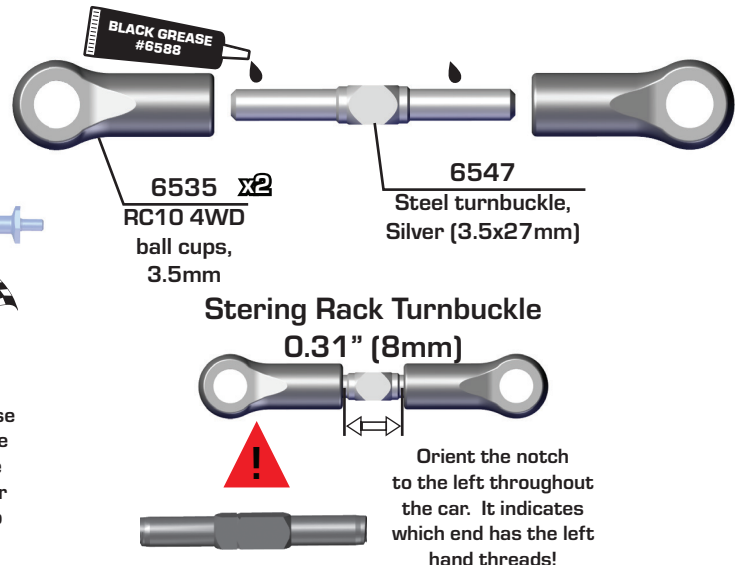
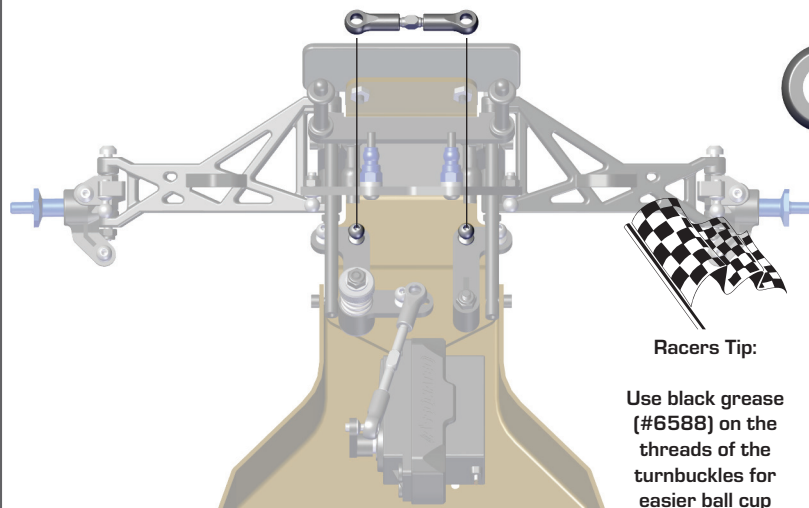

:: Turnbuckles Build - Bag F - Step 2

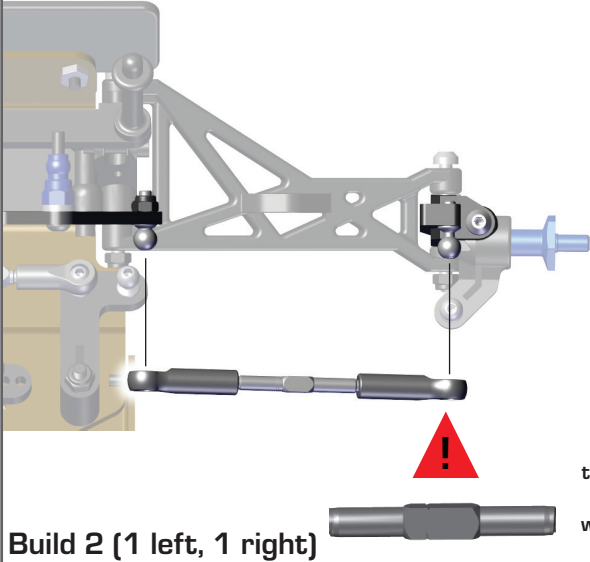

Build 2 (1 left, 1 right)



Racers Tip:

Use black grease (#6588) on the threads of the turnbuckles for easier ball cup installation!

Orient the notch to the left throughout the car. It indicates which end has the left hand threads!

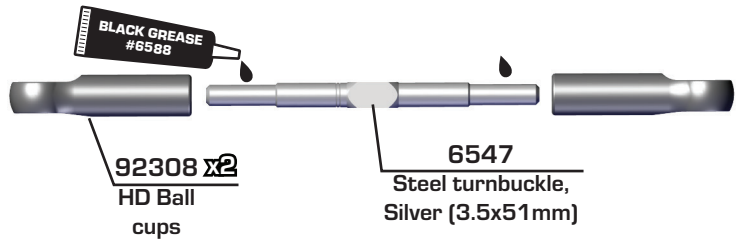

Front Camber Turnbuckle
1.10" (28.00mm)

Recommended turnbuckle lengths are approximate.
Final recommended settings:
0 degree Front Toe in
-2 Degree Front Camber
-3 Degree Rear Camber.

:: Turnbuckles Build - Bag F - Step 3

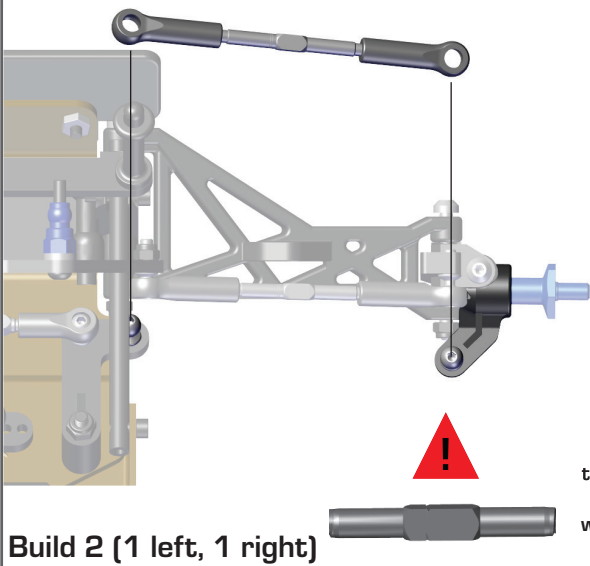

Build 2 (1 left, 1 right)



Racers Tip:

Use black grease (#6588) on the threads of the turnbuckles for easier ball cup installation!

Orient the notch to the left throughout the car. It indicates which end has the left hand threads!

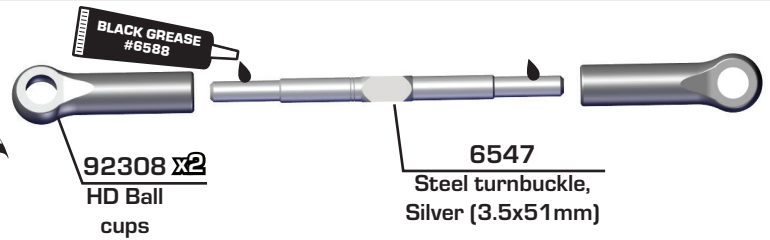

Steering Turnbuckle
1.32" (33.50mm)

Recommended turnbuckle lengths are approximate.
Final recommended settings:
0 degree Front Toe in
-2 Degree Front Camber
-3 Degree Rear Camber.

:: Turnbuckles Build - Bag F - Step 4

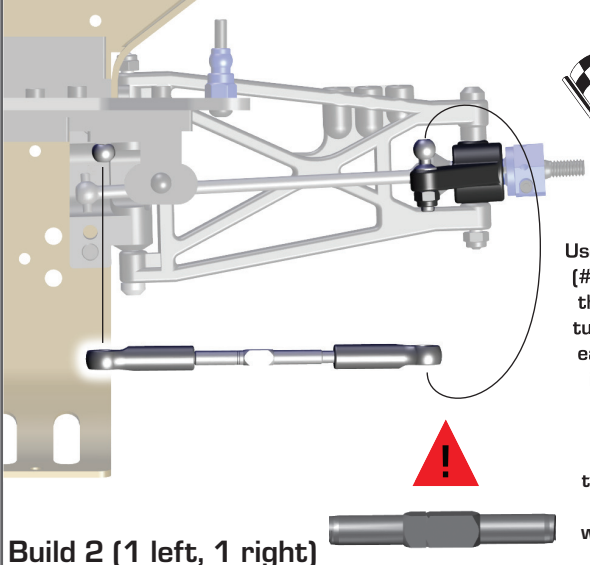

Build 2 (1 left, 1 right)



Racers Tip:

Use black grease (#6588) on the threads of the turnbuckles for easier ball cup installation!

Orient the notch to the left throughout the car. It indicates which end has the left hand threads!

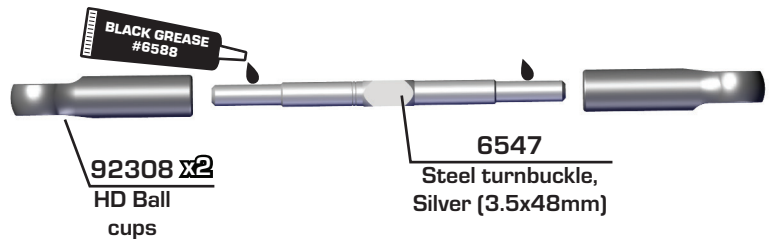

Rear Camber Turnbuckle
1.32" (33.50mm)

Recommended turnbuckle lengths are approximate.
Final recommended settings:
0 degree Front Toe in
-2 Degree Front Camber
-3 Degree Rear Camber.

:: Shocks Build - Bag G - Step 1

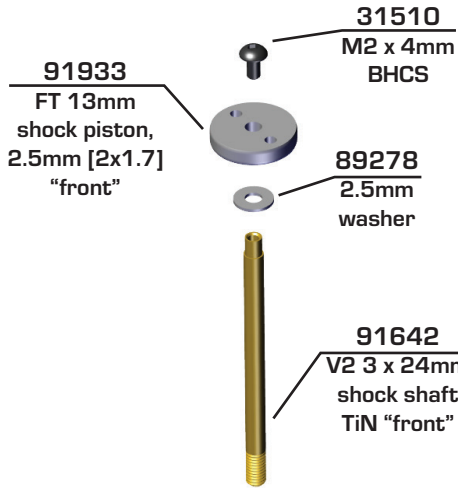

Build x2 front shocks

!
Mount the shock pistons with the number facing up!



Racers Tip:

Use marker to mark over the numbers on the pistons to make them easily visible!

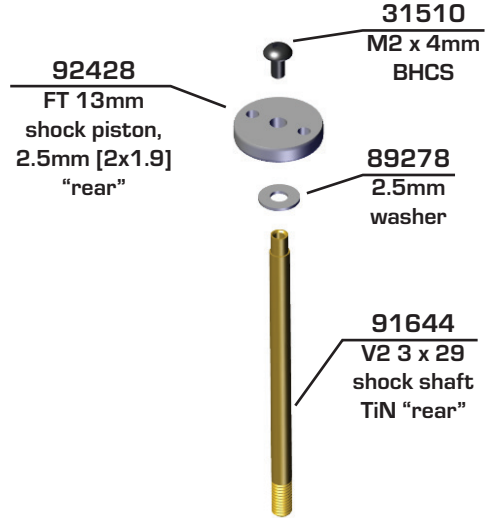

Build 2 rear shocks

:: Shocks Build - Bag G - Step 2

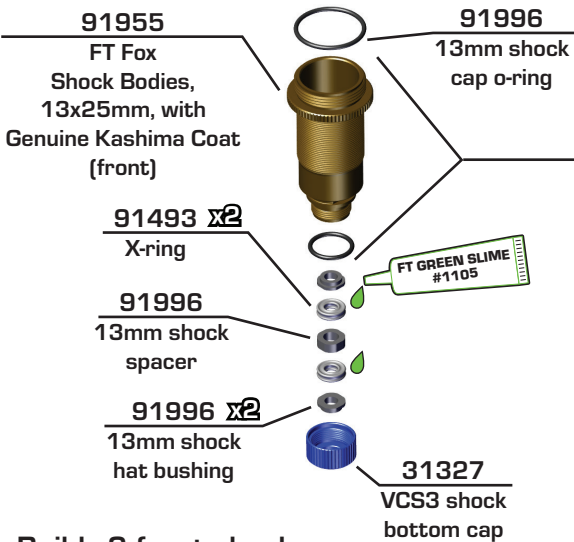

Build x2 front shocks

!
Lightly rub shock oil on the O-ring before installation!



Racers Tip:

Coating the O-rings with green slime (#1105) helps seal & reduce O-ring swell! Green slime not included in kit!

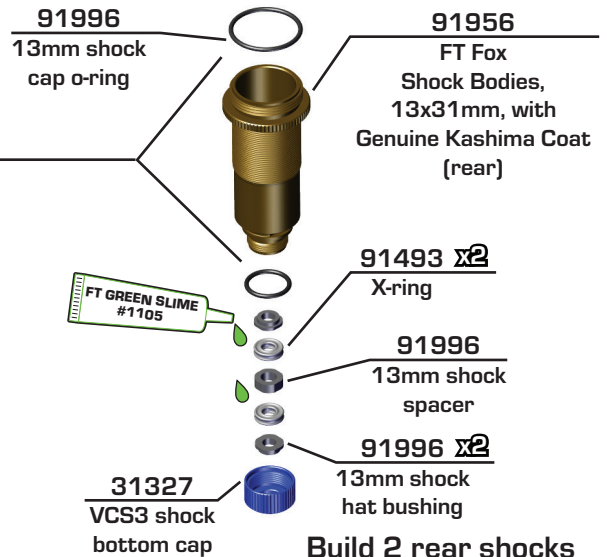

Build 2 rear shocks

:: Shocks Build - Bag G - Step 3



Lightly rub shock fluid or green slime on threads.

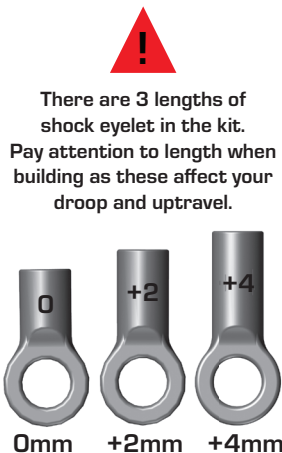

Build x2 front shocks

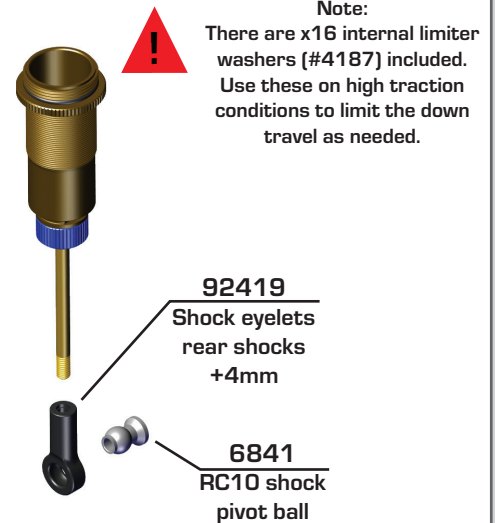

Build 2 rear shocks

:: Shocks Build - Bag G - Step 4

SHOCK FLUID

SHOCK FLUID

Front Shock: 35wt #5429
Rear Shock: 30wt #5422

Steps 2-3 Steps 4-5 Steps 6-7 Step 8

91926
13mm Shock Cap

Shock Bleeding Steps:

1. Before assembly, get each bleed screw and thread it 1-2 turns into the shock cap, then remove the screw. This will make it easier when you are bleeding your shocks.
2. Pull shock shaft down.
3. Fill shock body 3/4 full with silicone shock fluid.
4. Slowly move the shock shaft up and down to remove air from under the piston.
5. Wait for bubbles to come to surface.
6. Fill shock body to top with silicone shock fluid.
7. Place a drop of oil in the cap and on cap threads.
8. Install cap (without bleed screw) and tighten completely.
9. Slowly compress shaft all the way to bleed excess silicone shock fluid out the hole in the cap (use rag around shock to catch excess fluid).
10. Install M2x4mm button head screw until snug while shaft is fully compressed.

31510
M2 x 4mm BHCS

Stroke

Stroke
Front: 26.5mm
Rear: 31.5mm

Steps 9-10

:: Shocks Build - Bag G - Step 5

91996 x4
13mm Threaded Collar O-ring

91928 x4
13mm Threaded Collar

Build x4

91944
13mm front spring, red (4.00lb)

91950
13mm rear spring, blue (2.20lb)

Racers Tip:

Use your finger to rub shock fluid on the O-ring for smoother adjustment!

:: Shocks Build - Bag G - Step 6

Screw collars to top.
Use to adjust ride height.

91966
13mm Shock Spring Cup (Front - 9mm)

Build x2 front shocks

91966
13mm Shock Spring Cup (Rear - 5mm)

Build x2 rear shocks

#91966 13mm Shock Spring Cups

0mm 5mm 9mm

:: Shocks Build - Bag G - Step 7

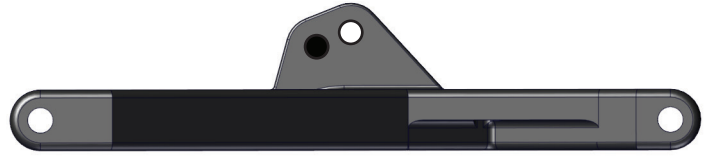
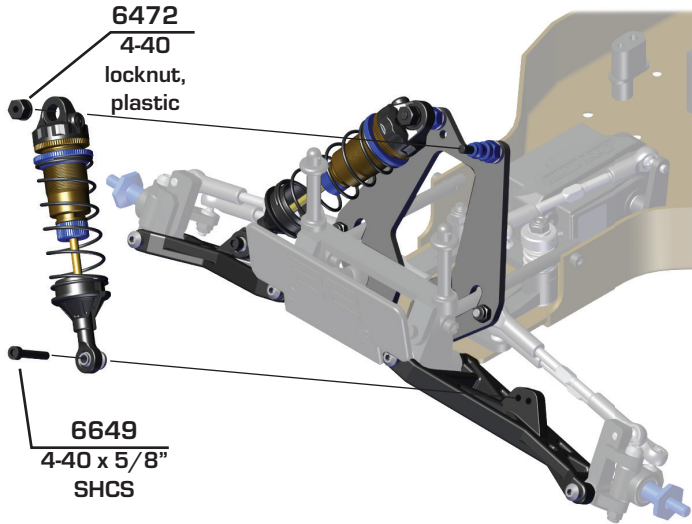

Build 2 (1 left, 1 right)

:: Shocks Build - Bag G - Step 8

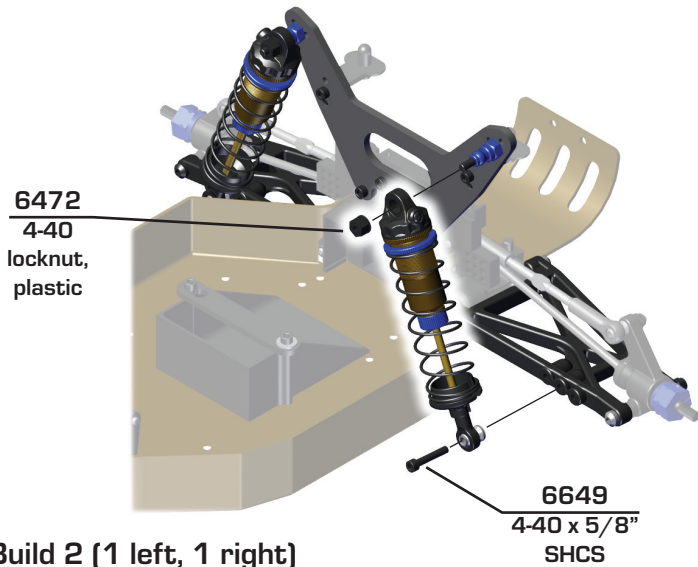

Build 2 (1 left, 1 right)

:: Transmission Build - Bag H - Step 1

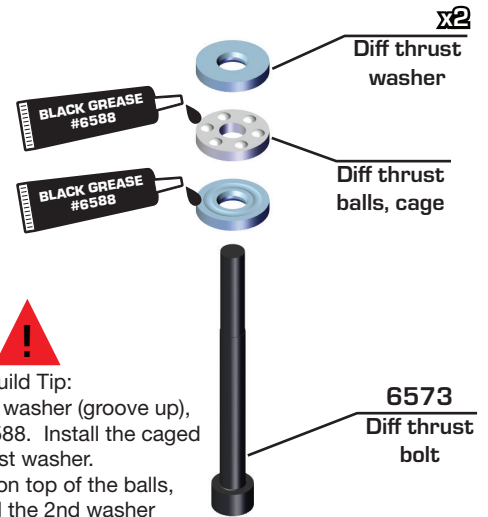
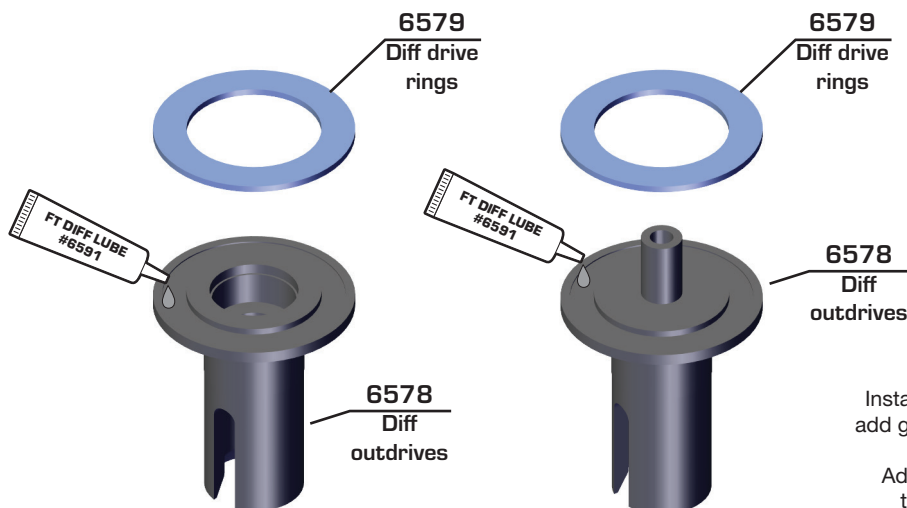

!
Build Tip:
Install the first washer (groove up),
add grease #6588. Install the caged
thrust washer.
Add grease on top of the balls,
then install the 2nd washer
(grooves down).

Transmission Build - Bag H - Step 2

6581 x12
Carbide diff balls, 3/32"

7812
Diff gear 45T

6589 x2
Bearing 5/32 x 5/16

FT DIFF LUBE #6591

!
Build Tip:
Do this entire step with the diff screw on the end of your wrench for better control.

Transmission Build - Bag H - Step 3

6575
Diff thrust nut

6582
Diff thrust spring

!
Compress spring first.

6575
Diff bolt cover

As you tighten the diff bolt, you will notice the T-nut ears moving closer to the bottom of the outdrive slot. This compresses the spring behind the T-nut. The spring should be completely compressed at the time the T-nut reaches the end of the slot.

Caution! Pay close attention to the feeling when the spring is completely compressed. Do not overtighten the bolt. When you feel the spring completely compressed, loosen the diff bolt 1/8 of a turn. Your diff should now operate smoothly but with resistance as the outdrives move in opposite directions.

After you have driven the car once, re-check the diff setting.

Transmission Build - Bag H - Step 4

6560
Complete Stealth transmission

6564
RC10WC Stealth transmission case black, right

6569
Idler gear

9601
Top shaft

3977 x4
Bearing 3/16 x 3/8"

6906
3/16 x 3/8" bearing
*** Not included in kit**

3976 x2
Bearing 3/8 x 5/8"

6564
RC10WC Stealth transmission case black, left

6569
Idler gear shaft

FT DIFF LUBE #6591

!
Install the diff with the diff bolt head facing the spur gear side of the transmission!

Transmission Build - Bag H - Step 5

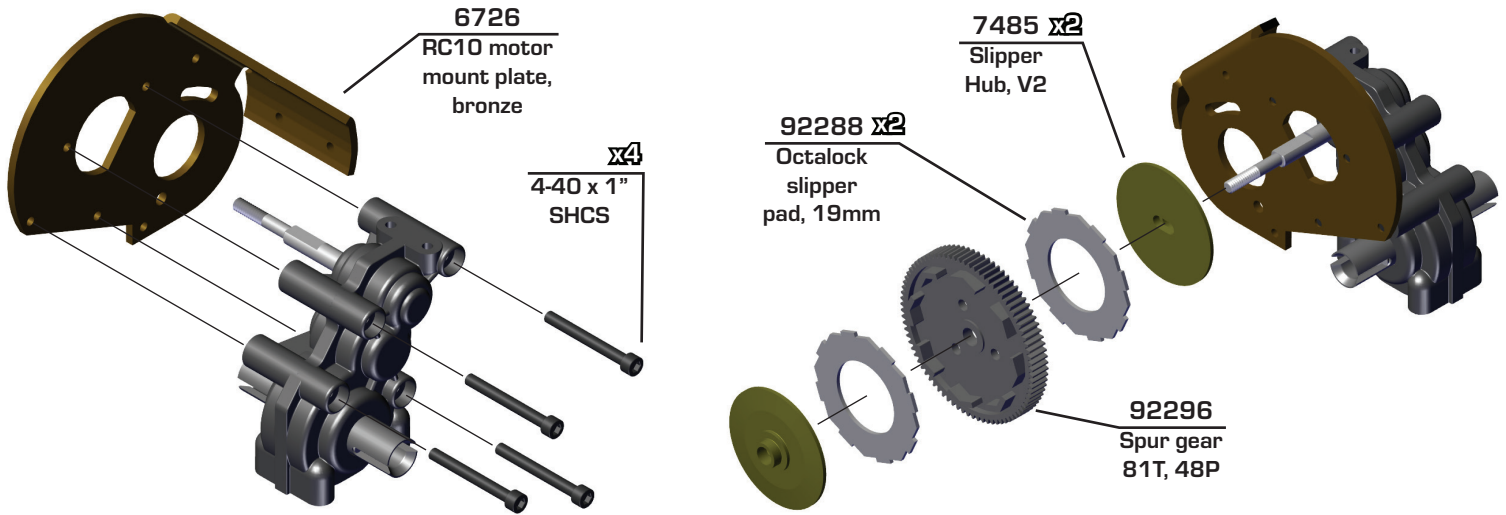

Transmission Build - Bag H - Step 6

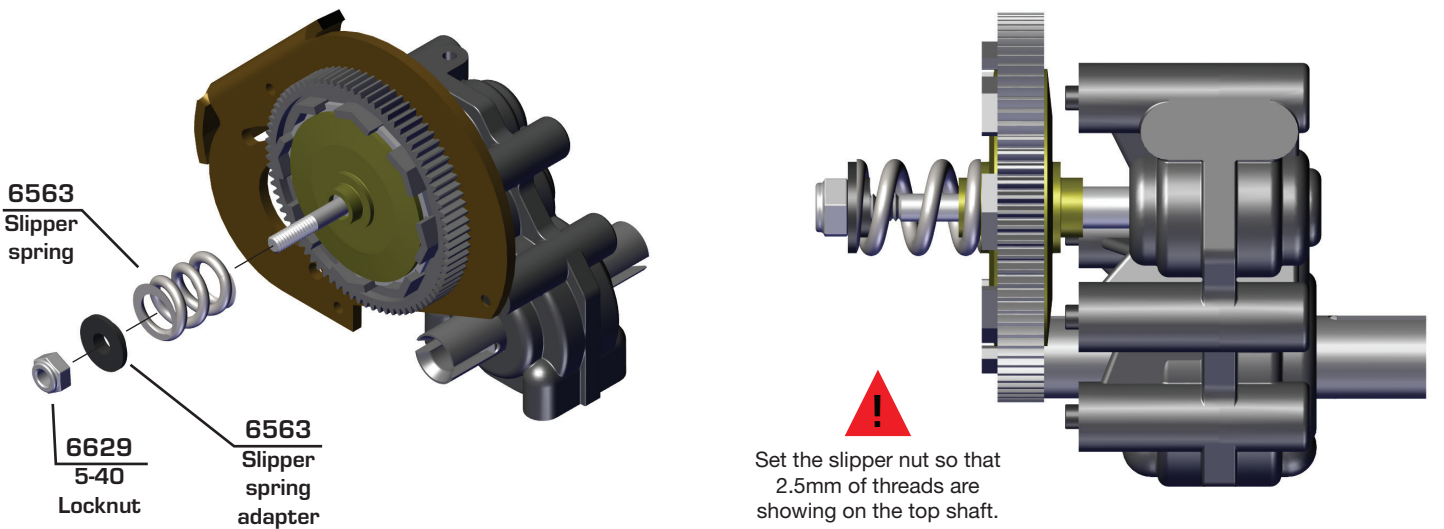

Transmission Build - Bag H - Step 7

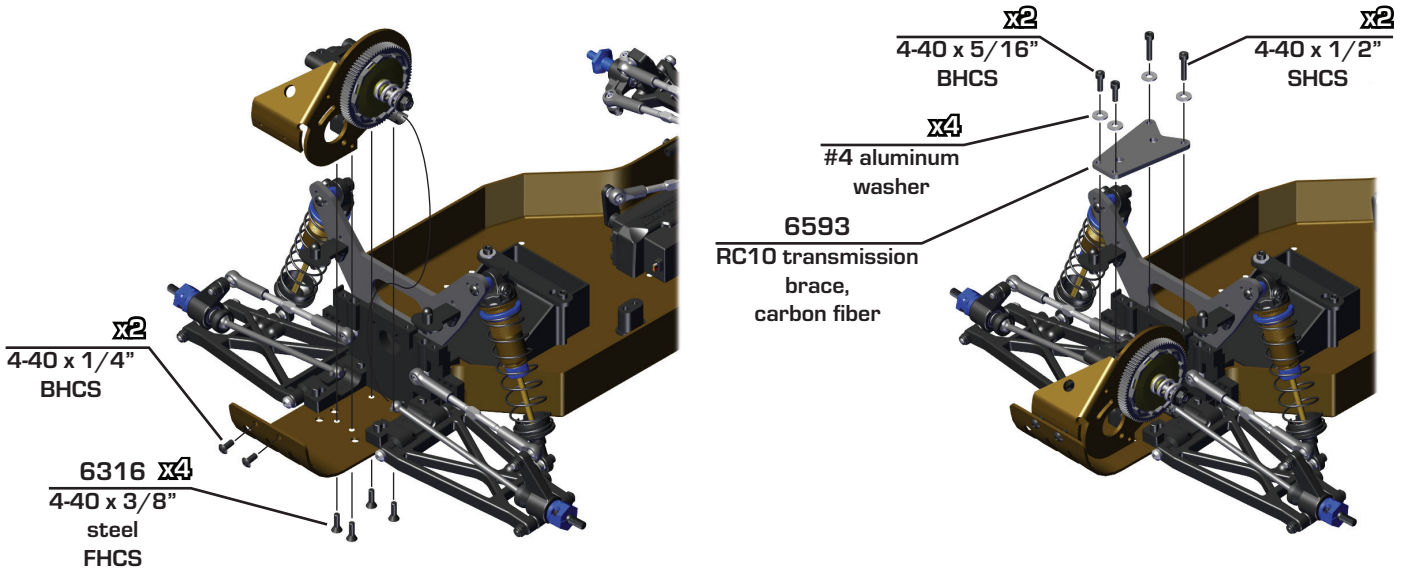

:: Transmission Build - Bag H - Step 8

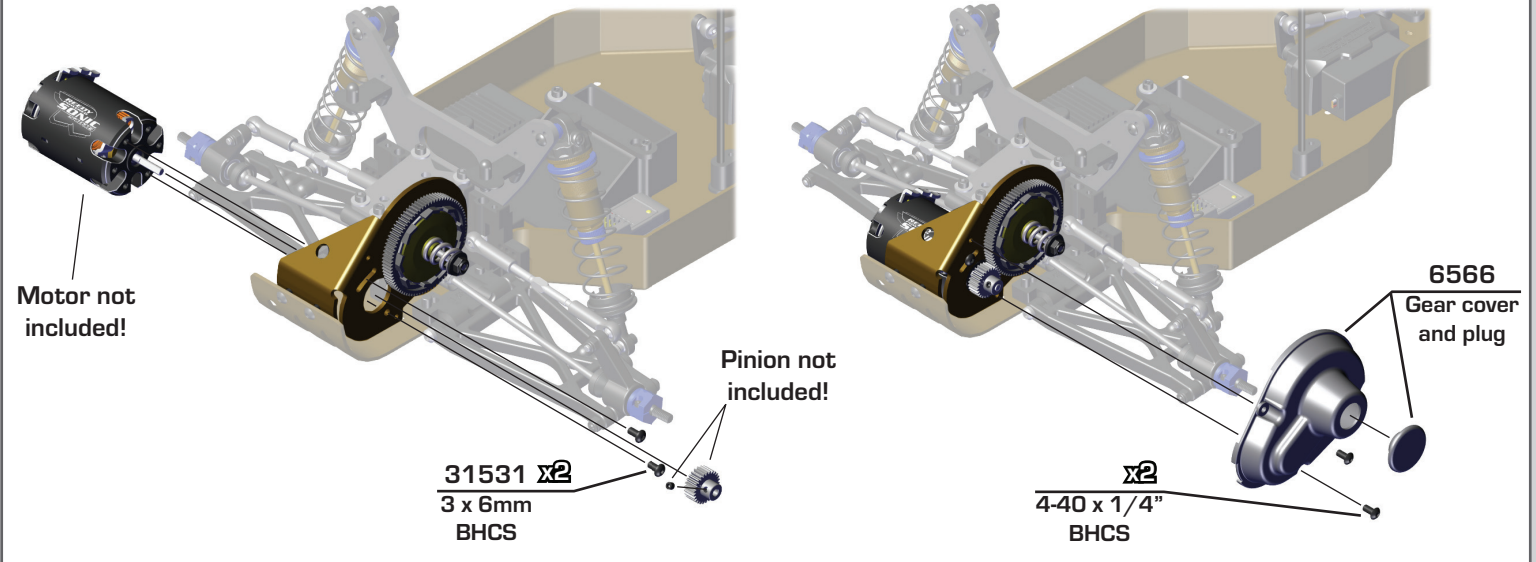

:: Transmission Build - Bag H - Step 9

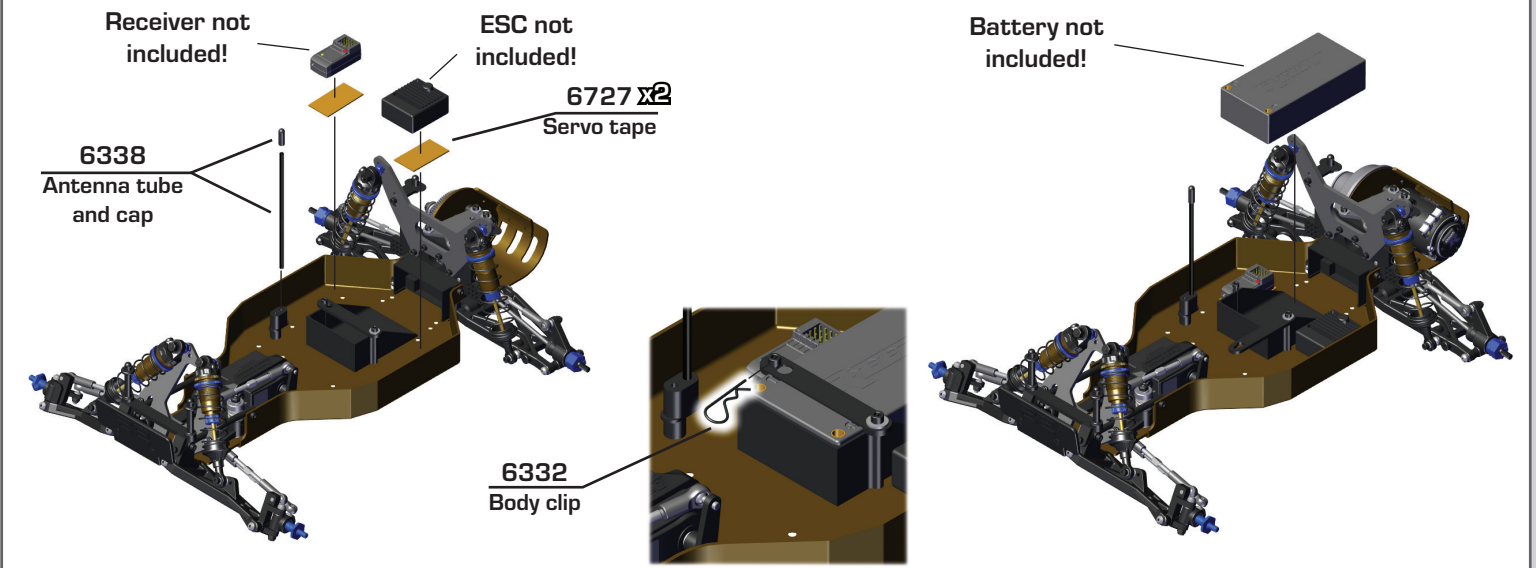

:: Wheels / Tires Build - Bag I - Step 1

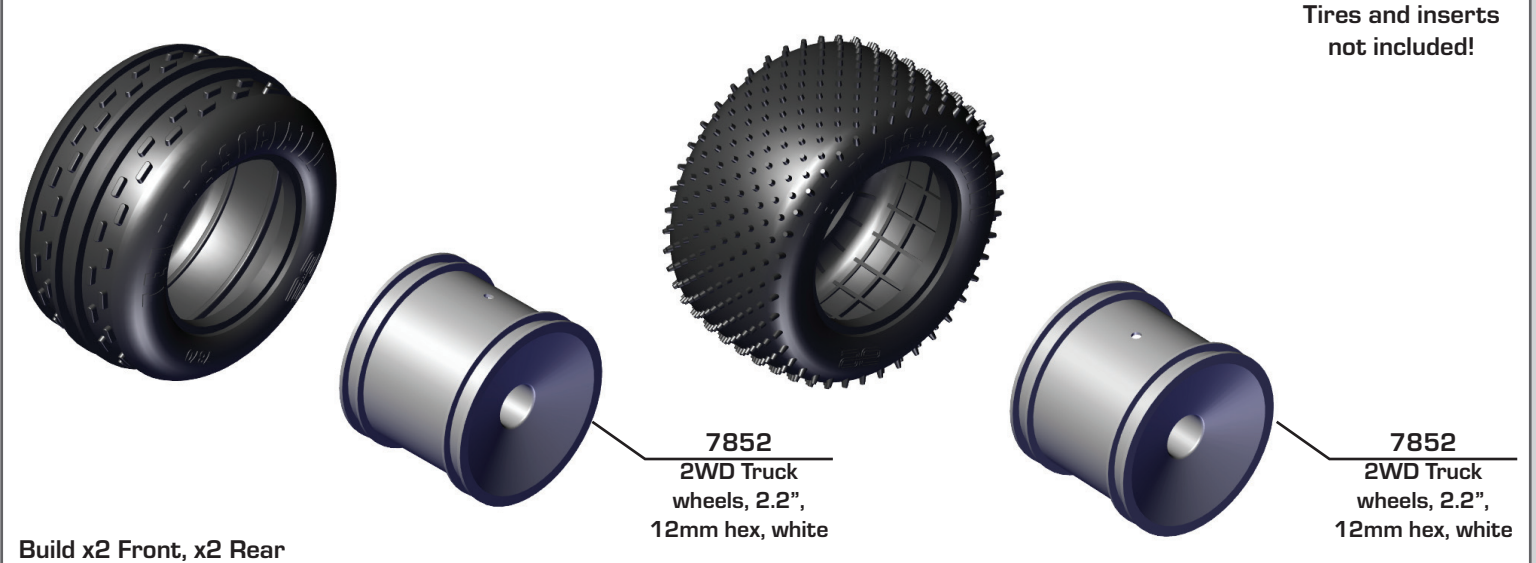

Wheels / Tires Build - Bag I - Step 2

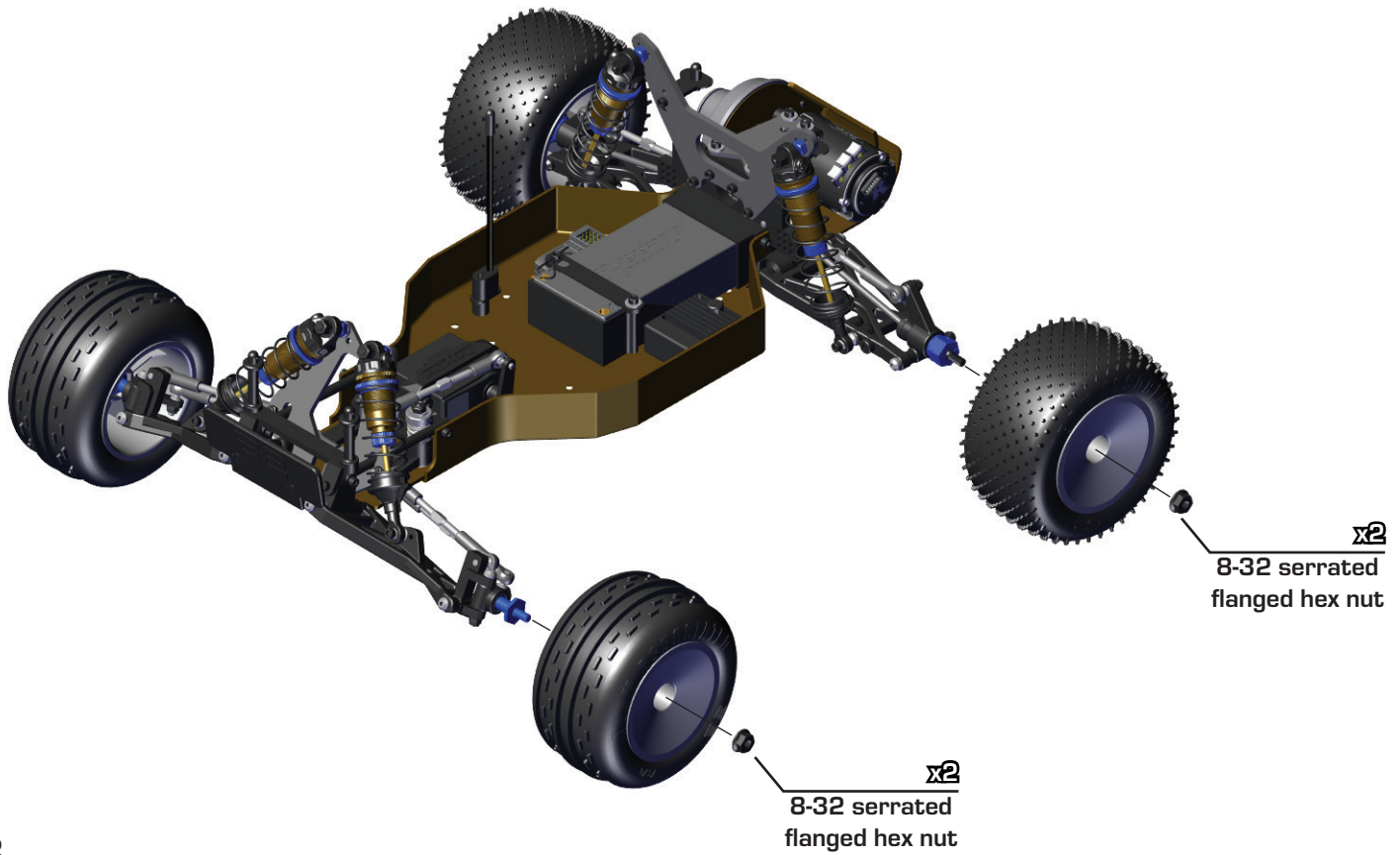

Wheels / Tires Build - Bag I - Step 3

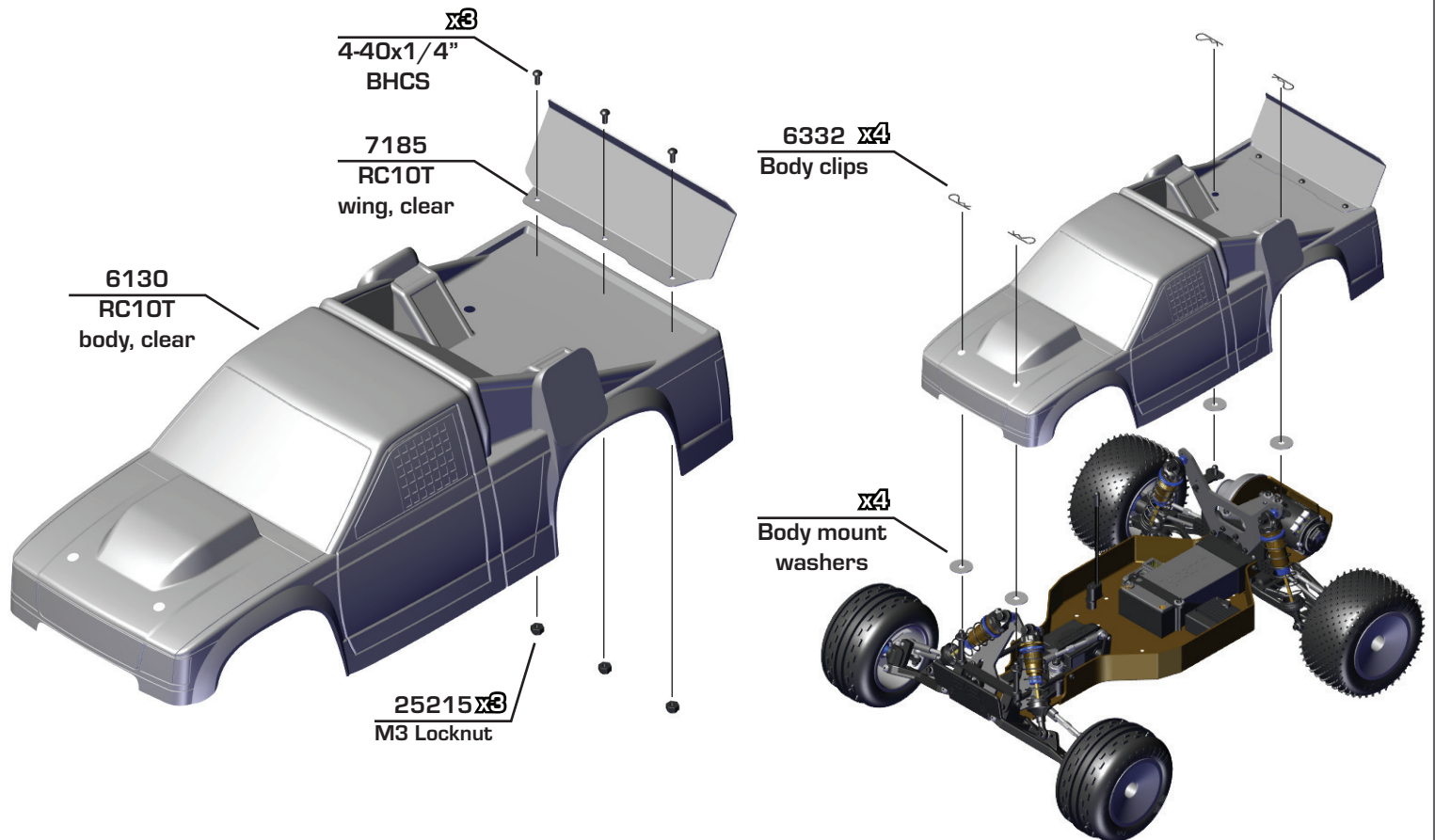

:: Painting Tips**Painting:**

Your Kit requires a clear polycarbonate body. You will need to prep the body before you can paint it. Wash the INSIDE thoroughly with warm water and liquid detergent (do not use any detergents with scents or added hand lotion ingredients!). Dry the body using a clean, soft, lint-free cloth. Use the supplied window masks to cover the windows from the INSIDE of the body (RC bodies get painted on the inside). Using high quality masking tape, apply tape to the inside of the body to create a design. Spray (use either rattle can or airbrush) the paint on the inside of the body (preferably dark colors first, lighter colors last). NOTE: ONLY use paint that is recommended for (polycarbonate) plastics. If you do not, you can destroy the body! After the paint has completely dried (usually after 24 hours), cut the body along the trim lines. Make sure to drill or use a body reamer to make the holes for the antenna if needed! Use hook and loop tape to secure the body to the side rails of the vehicle.

:: Notes

TEAM ASSOCIATED RC10 SETUP SHEET

Driver: Scott Brown - 2nd place (1991-1996) Class Date: 2025
 Track: New Orleans Hotel/Casino Arena, Las Vegas, NV Event: 2025 Team Associated Vintage Champs
 Conditions: Indoor Outdoor Temp: _____ Rev: 1

Ride Height / Wheelbase

Front Ride Height:
Arms level

Rear Ride Height:
Bones level

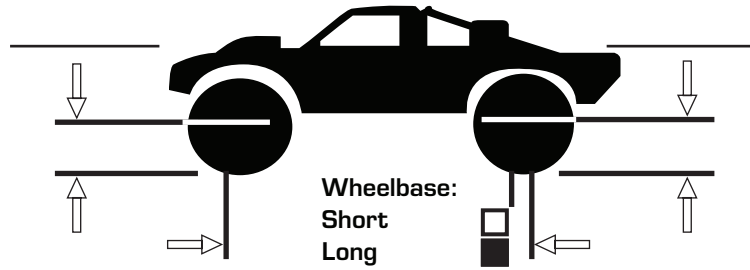

Rear Suspension

Camber: -2 deg

Rear Hub Carriers:
0°
1.5°

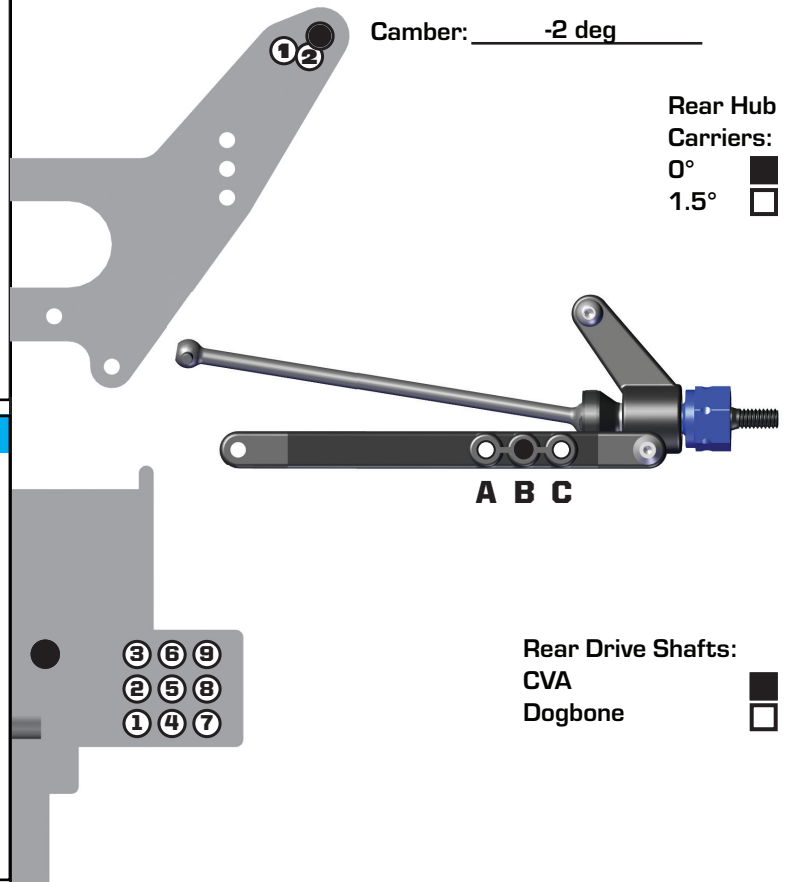

Front Suspension

Caster: 25° 30°
 Camber: -1 deg
 Toe: 1 deg out

Steering Block:
Inline Trailing
 Bump Steer Spacers:
Inside: 0
 Outside: 0

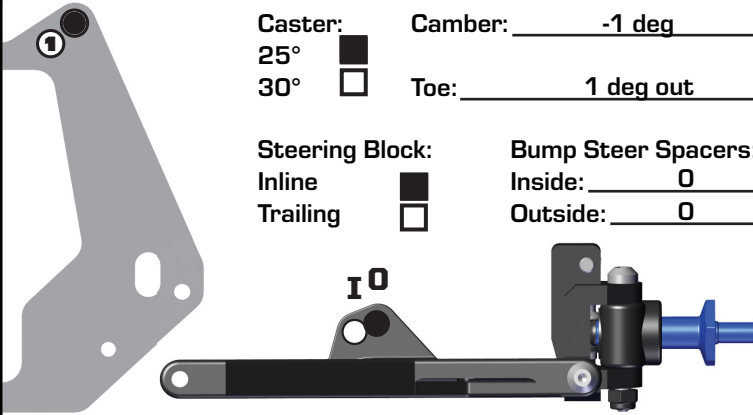

Front Shocks

Shock Body: Kit Shock Shaft: 27.5mm
 Spring: AE Grey 13mm Piston: 2x1.6+1x1.2
 Shock Fluid: 35wt Eyelet: 2
 Limiters: Int: _____ Ext: _____ Stroke: 23mm
 Notes: _____

Rear Shocks

Shock Body: Kit Shock Shaft: 35mm
 Spring: AE Green 13mm Piston: 2x1.7+1x1.3
 Shock Fluid: 30wt Eyelet: 0
 Limiters: Int: _____ Ext: _____ Stroke: 29.5mm
 Notes: _____

Motor / Battery

Motor & Wind: Reedy SP5 13.5T w/Titanium Screws
 Pinion: 25T Spur Gear: 78T
 Battery: _____

Radio / ESC Settings

Radio: _____
 Throttle / Brake: e.p.a: _____ Expo: _____
 Servo: _____ Steering Expo: _____
 ESC: _____
 ESC Settings: _____

Drivetrain

Slipper: V2 slipper
 2 Pads 3 Pads 4 Pads
 Notes: _____

Other

Body Type: _____
 Wing Type: _____

Weight

Battery Placement: _____
 Ballast Weight: _____
 Notes: _____

Rear Tires

Tire: _____
 Compound: _____
 Insert: _____ Wheel: _____

Front Tires

Tire: _____
 Compound: _____
 Insert: _____ Wheel: _____

Track Info

Surface:	Traction:	Conditions:	Moisture:
Dirt <input type="checkbox"/>	Low <input type="checkbox"/>	Grooved <input type="checkbox"/>	Wet <input type="checkbox"/>
Carpet <input type="checkbox"/>	Med <input type="checkbox"/>	Dusty <input type="checkbox"/>	Damp <input type="checkbox"/>
Astro <input type="checkbox"/>	High <input type="checkbox"/>	Smooth <input type="checkbox"/>	Dry <input type="checkbox"/>
Multi <input type="checkbox"/>		Bumpy <input type="checkbox"/>	
		Hard Pack <input type="checkbox"/>	
		Loamy <input type="checkbox"/>	

Race and Vehicle Comments

Qualify: _____ Main: _____ Finish: _____ TQ: _____
 Comments: _____

TEAM ASSOCIATED RC10 SETUP SHEET

Driver: _____ Date: _____
 Track: _____ Event: _____
 Conditions: _____ Indoor Outdoor Temp. _____ Rev:1

Ride Height / Wheelbase

Front Ride Height: _____

Rear Ride Height: _____

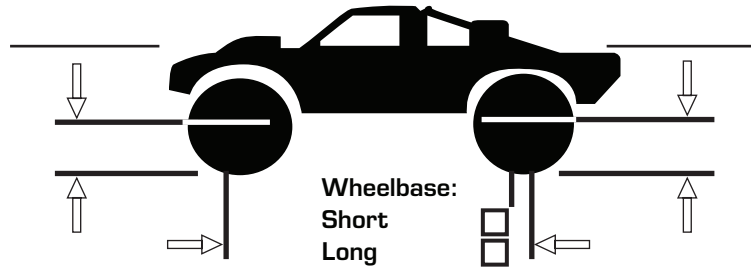

Wheelbase:
Short
Long

Rear Suspension

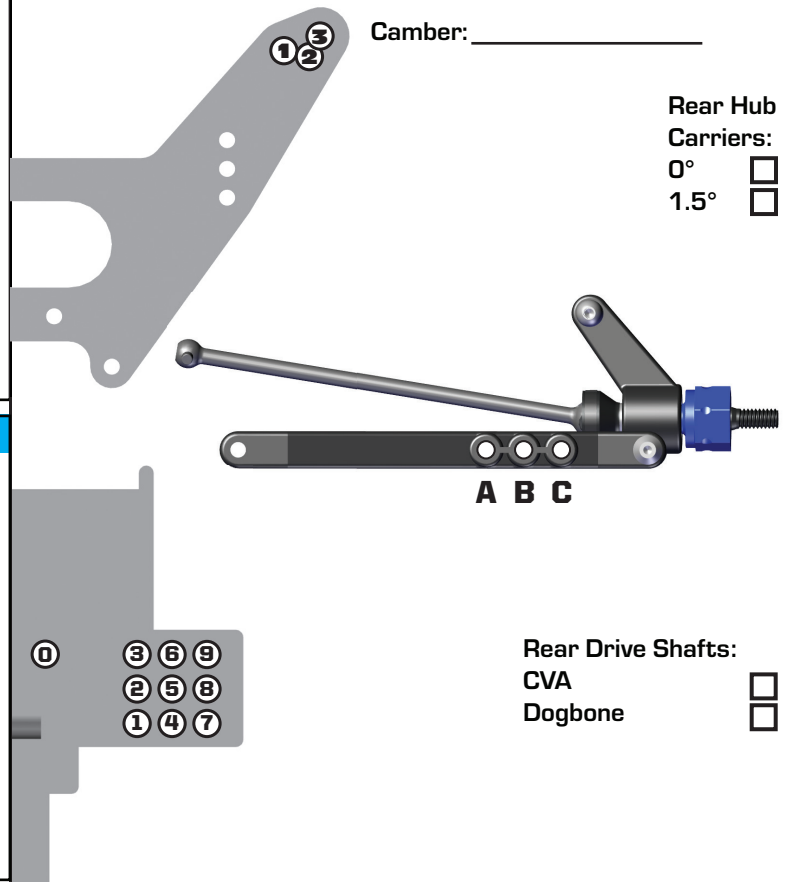

Camber: _____

Rear Hub Carriers:
0°
1.5°

A B C

Rear Drive Shafts:
CVA
Dogbone

Front Suspension

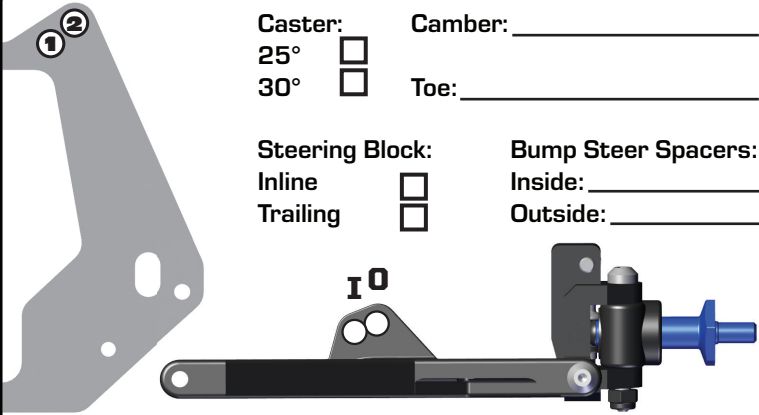

Caster: 25°
30° Camber: _____
Toe: _____

Steering Block: Inline
Trailing Bump Steer Spacers:
Inside: _____
Outside: _____

Front Shocks

Shock Body: _____ Shock Shaft: _____
 Spring: _____ Piston: _____
 Shock Fluid: _____ Eyelet: _____
 Limiters: Int: _____ Ext: _____ Stroke: _____
 Notes: _____

Rear Shocks

Shock Body: _____ Shock Shaft: _____
 Spring: _____ Piston: _____
 Shock Fluid: _____ Eyelet: _____
 Limiters: Int: _____ Ext: _____ Stroke: _____
 Notes: _____

Motor / Battery

Motor & Wind: _____
 Pinion: _____ Spur Gear: _____
 Battery: _____

Radio / ESC Settings

Radio: _____
 Throttle / Brake: e.p.a: _____ Expo: _____
 Servo: _____ Steering Expo: _____
 ESC: _____
 ESC Settings: _____

Drivetrain

Slipper: _____
 2 Pads 3 Pads 4 Pads
 Notes: _____

Other

Body Type: _____
 Wing Type: _____

Weight

Battery Placement: _____
 Ballast Weight: _____
 Notes: _____

Rear Tires

Tire: _____
 Compound: _____
 Insert: _____ Wheel: _____

Front Tires

Tire: _____
 Compound: _____
 Insert: _____ Wheel: _____

Track Info

Surface:	Traction:	Conditions:	Moisture:
Dirt <input type="checkbox"/>	Low <input type="checkbox"/>	Grooved <input type="checkbox"/>	Wet <input type="checkbox"/>
Carpet <input type="checkbox"/>	Med <input type="checkbox"/>	Dusty <input type="checkbox"/>	Damp <input type="checkbox"/>
Astro <input type="checkbox"/>	High <input type="checkbox"/>	Smooth <input type="checkbox"/>	Dry <input type="checkbox"/>
Multi <input type="checkbox"/>		Bumpy <input type="checkbox"/>	
		Hard Pack <input type="checkbox"/>	
		Loamy <input type="checkbox"/>	

Race and Vehicle Comments

Qualify: _____ Main: _____ Finish: _____ TQ: _____
 Comments: _____



Associated Electrics, Inc.
21062 Bake Parkway Lake Forest, CA 92630 USA

call: (949) 544-7500 - fax: (949) 544-7501
Check out the following web sites for all of our kits, current products,
new releases, setup help, tips, and racing info!
www.AssociatedElectrics.com

FOLLOW US ON SOCIAL MEDIA



TeamAssociated
ReedyPower
ElementRC
FactoryTeam51



@TeamAssociatedRC
@ReedyPower
@Element_RC
@FactoryTeam_RC



@Team_Associated
@ReedyPower



@Associated_Electrics



TeamAssociatedRC
ElementRC



TeamAssociated
Reedy
Element-rc