

1:10 Scale 2WD Electric Off Road
Competition Sprint Car Kit

RC10
SPRINT
EDITION



TEAM ASSOCIATED



1:10 Scale 2WD Electric Off Road Competition Sprint Car Kit Manual

#6057 RC10 Sprint Car Kit



CHAMPIONS by DESIGN

AssociatedElectrics.com

TEAM ASSOCIATED

:: Introduction

Thank you for purchasing this Team Associated product. This assembly manual contains instructions and tips for building and maintaining your new Kit. Please take a moment to read through this manual to help familiarize yourself with these steps.

We are continually changing and improving our designs; therefore, actual parts may appear slightly different than in the illustrations. New parts will be noted on supplementary sheets located in the appropriate parts bags. Check each bag for these sheets before you start to build.

:: KIT Features

Features in the RC10 Sprint Car Kit:

- New Team Associated clear sprint car body and wing included
- Black anodized 6061 aluminum chassis, nose plate and motor plates
- Fiberglass front and rear shock towers
- Hard Anodized shock bodies
- New front wing and mounting system
- New Factory Team 12mm hex front steering block
- New Factory Team 12mm hex front axle
- Factory Team 12mm Hex rear CVA's included
- 12mm Hex B7 wheels included
- Heavy Duty Metric Ball Studs
- All New RC10 B6 Gear Diff compliant transmission case
- New designed motor plates with new transmission case
- Heavy Duty Ball Cups and 3.5mm adjustable turnbuckles
- Multiple rear arm mount degrees included
- 1.5 degree rear hub and 0 degree rear hubs included
- All Black plastics + white 1.5 degree rear hubs
- Full ball bearings included
- New Team Associated livery decals included
- V2 slipper system included
- Independent suspension with durable long front arms and refined geometry
- World's Car bellcrank steering
- Spring Car dirt tires included
- All new sprint car wing mounting system

:: Additional

Your new RC10 Kit comes as a kit. There are some items you will need to complete your kit (refer to website for suggestions):

- R/C two channel surface frequency radio system
- Electronic Speed Control (ESC)
- Steering Servo
- 2S, 7.4V Lipo stick battery or 7.2V NiMH battery
- Peak detection battery charger
- Retaining Ring Pliers
- Polycarbonate specific paint
- Pinion gear, size to be determined by type and wind of motor you use
- R/C Electric Motor
- Servo Horn (AE #89007)
- Thread Lock (AE #1596)

Tools included:

- Allen wrenches (.035", .050", 1/16", 3/32")
- Shock building tool

:: Other Helpful Items

- Silicone Shock Fluid (Refer to website for complete listings)
- Tire Adhesive (AE #1597)
- Shock Pliers (AE #1681)
- Wire Cutters / Hobby Knife
- Body Scissors (AE #1737)
- Green Slime shock lube (AE #1105)
- Needle Nose Pliers
- Reamer / Hole Punch (AE #1499)
- Calipers or a Precision Ruler
- Soldering Iron











Associated Electrics, Inc.
21062 Bake Parkway
Lake Forest, CA 92630











Customer Service
Tel: 949.544.7500
Fax: 949.544.7501

:: Hardware - 1:1 Scale View









Cap Head (shcs)

	4-40 x 1/4"
	4-40 x 5/16"
	4-40 x 3/8"
	4-40 x 1/2"
	4-40 x 5/8"
	4-40 x 3/4"
	4-40 x 1"
	1.6x5mm (91611)
	3x6mm (25658)
	3x8mm (89223)
	3x10mm (25713)

Flat Head (fhcs)

	4-40 x 1/4"
	4-40 x 3/8"
	4-40 x 1/2"
	8-32 x 1/4" (6316)
	8-32 x 1/2" (6316)
	8-32 x 7/8" (6316)
	3x10mm (25202)
	3x26mm (89243)

Button Head (bhcs)

	0-80 x 3/16"
	4-40 x 3/16"
	4-40 x 1/4"
	4-40 x 5/16"
	4-40 x 3/8"
	8-32 x 1/4"
	2.5x10mm (31522)
	3x6mm (31531)







LP Socket Head (shcs)

	3x8mm (41096)
--	----------------------



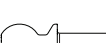
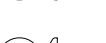
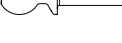





Set Screws

	4-40x3/32"
	4-40x1/8"
	4-40x5/16"
	8-32x5/8"





Ballstuds

	Silver 8mm Long (31284)
	HD 4mm (91451)
	Titanium HD 42mm (91750)
	HD 6mm (91047)
	Titanium HD 6mm (91751)
	HD 8mm (91048)
	Titanium HD 8mm (91752)
	HD 10mm (91049)
	Titanium HD 10mm (91753)

Nuts (lock/plain)

	4-40 Small Pattern Plain Nut
	4-40 Nuts
	5-40 Locknut
	8-32 Steel Locknut
	M3 Nut (91477)
	M3 Alum. Locknut, Blue (31550)
	M3 Locknut, Black (25215)
	M4 Serrated w/Flange (91738)
	FT M4 Locknuts w/Flange, M4 Locknut (31551)

Bearings

	3/16 x 3/8 x 1/8" (3977)
	3/16 x 5/16 x 1/8" (6909)
	5x10x4mm (91560)
	10x15x4mm (91563)

Shims and Washers

	.030 Nylon Spacer (4187)
	#4 Washer OR Alum. Washer, 1mm (31385)
	5mm x 9.5mm 0.17mm
	#8 Aluminum Thick Washer

Clips

	E-clip 1/8" (6299)
---	---------------------------

Notes:

:: Table of Contents

1..... Cover	11..... Turnbuckles Build (Bag F)
2..... Introduction	13..... Shocks Build (Bag G)
3..... 1:1 Hardware "Fold Out"	15..... Electronics Build (Bag H)
4..... Table of Contents	17..... Servo Build (Bag I)
5..... Nose Plate / Steering Build (Bag A)	17..... Wheels, Tires and Body Install (Bag J)
6..... Front Suspension Build (Bag B)	21..... Notes
7..... Rear Bulkhead Build (Bag C)	22..... Back Cover
7..... Transmission Build (Bag D)	
10..... Rear Suspension Build (Bag E)	

:: Notes

This symbol indicates a special note or instruction in the manual.



There is a 1:1 hardware foldout page in the front of the manual. To check the size of a part, line up your hardware with the correct drawing until you find the exact size.

Associated Electrics, Inc.
21062 Bake Parkway
Lake Forest, CA 92630



Customer Service
Tel: 949.544.7500
Fax: 949.544.7501

:: Nose Plate / Steering Build - Bag A - Step 1

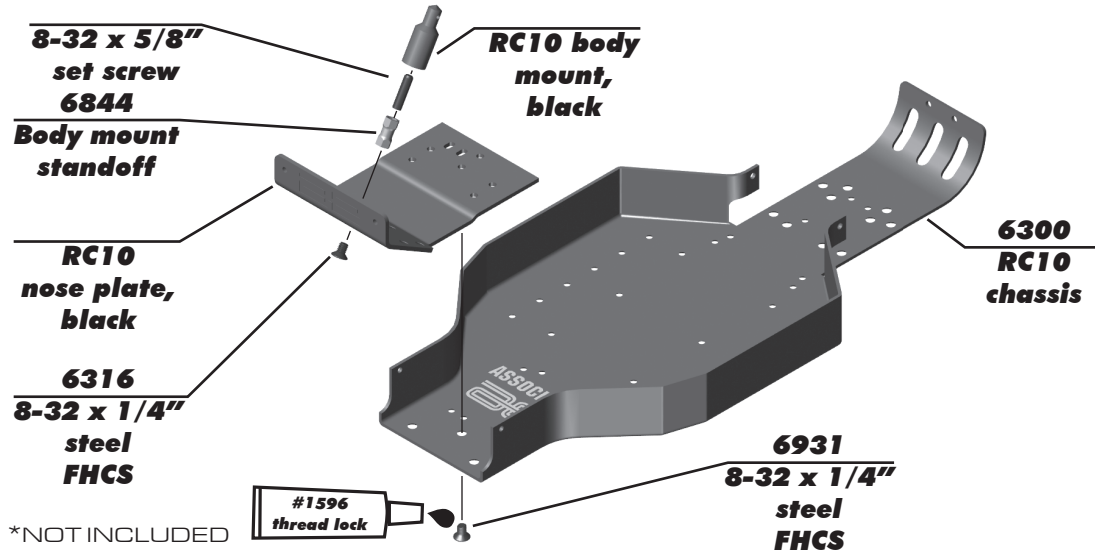

:: Nose Plate / Steering Build - Bag A - Step 2

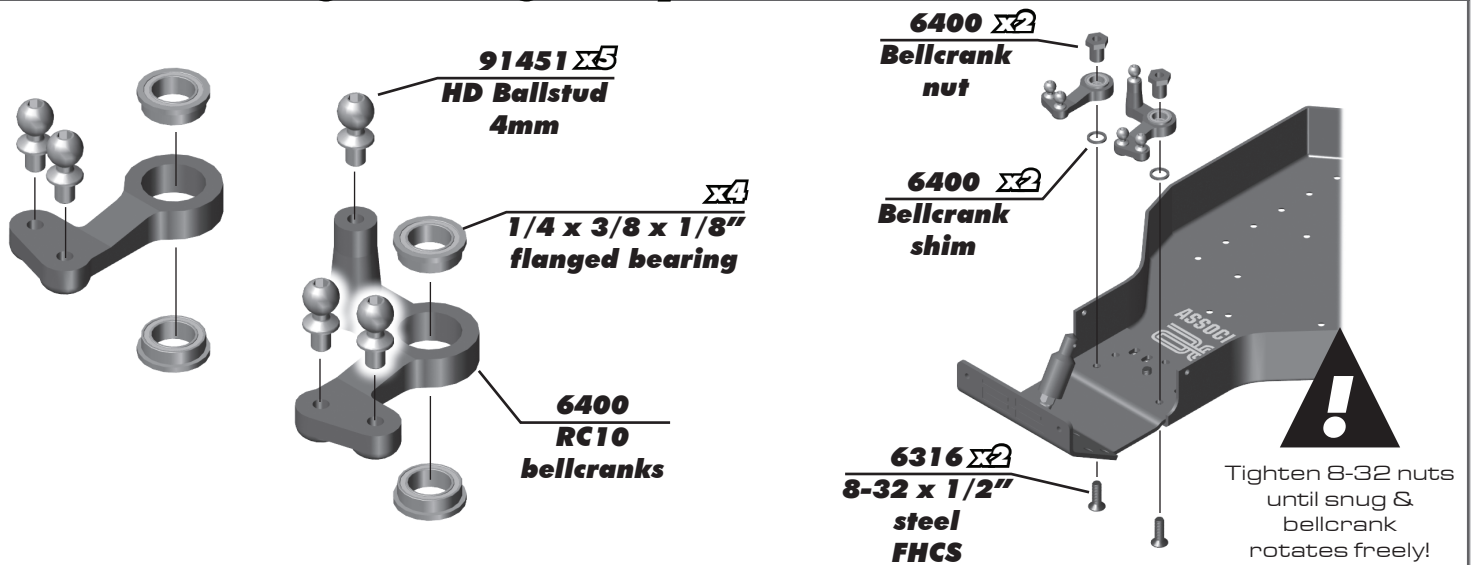

:: Nose Plate / Steering Build - Bag A - Step 3

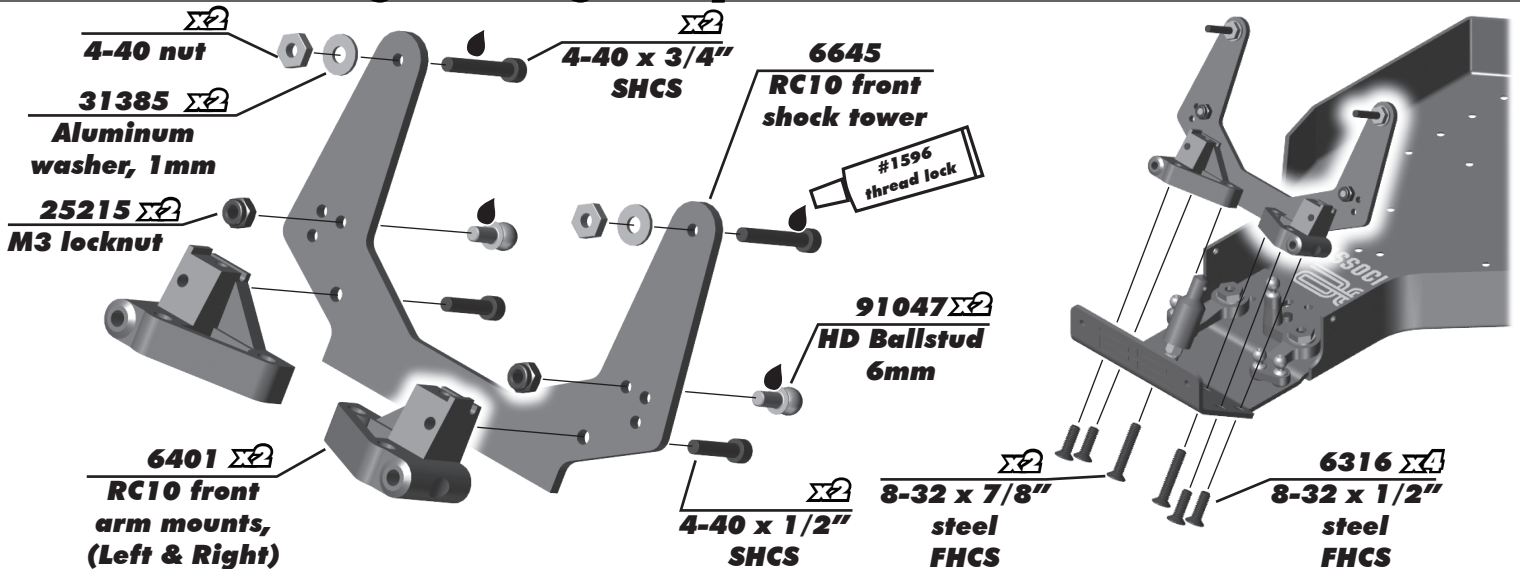

:: Front Suspension Build - Bag B - Step 1

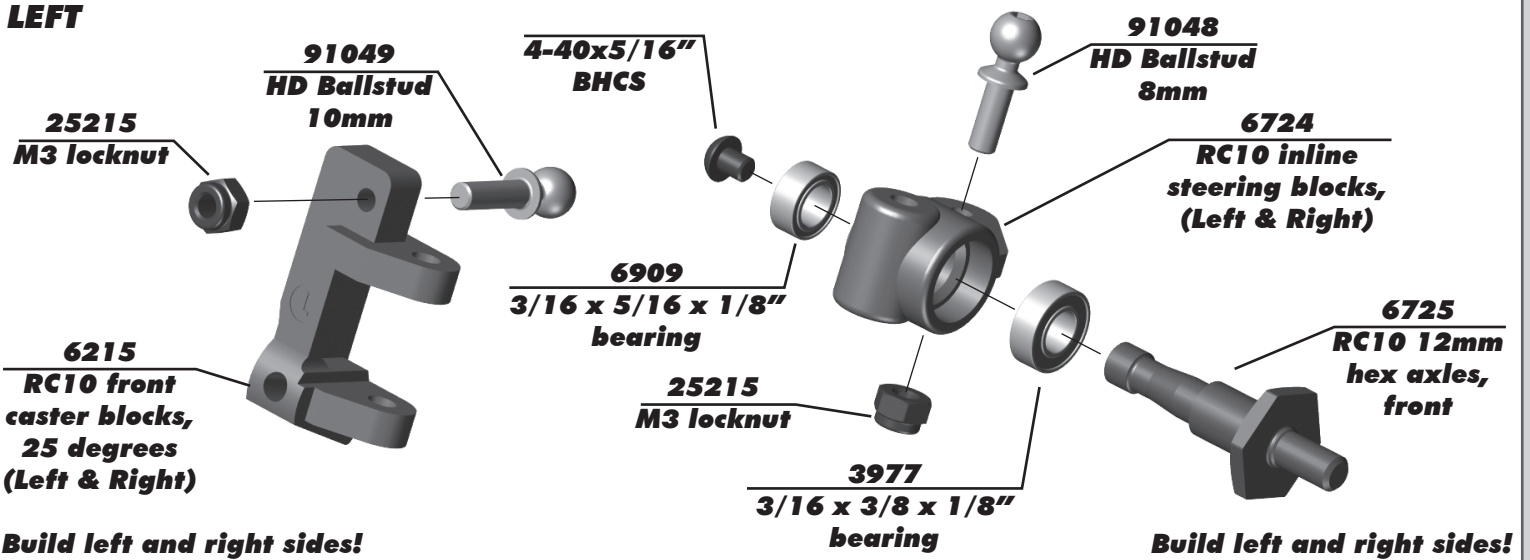

:: Front Suspension Build - Bag B - Step 2

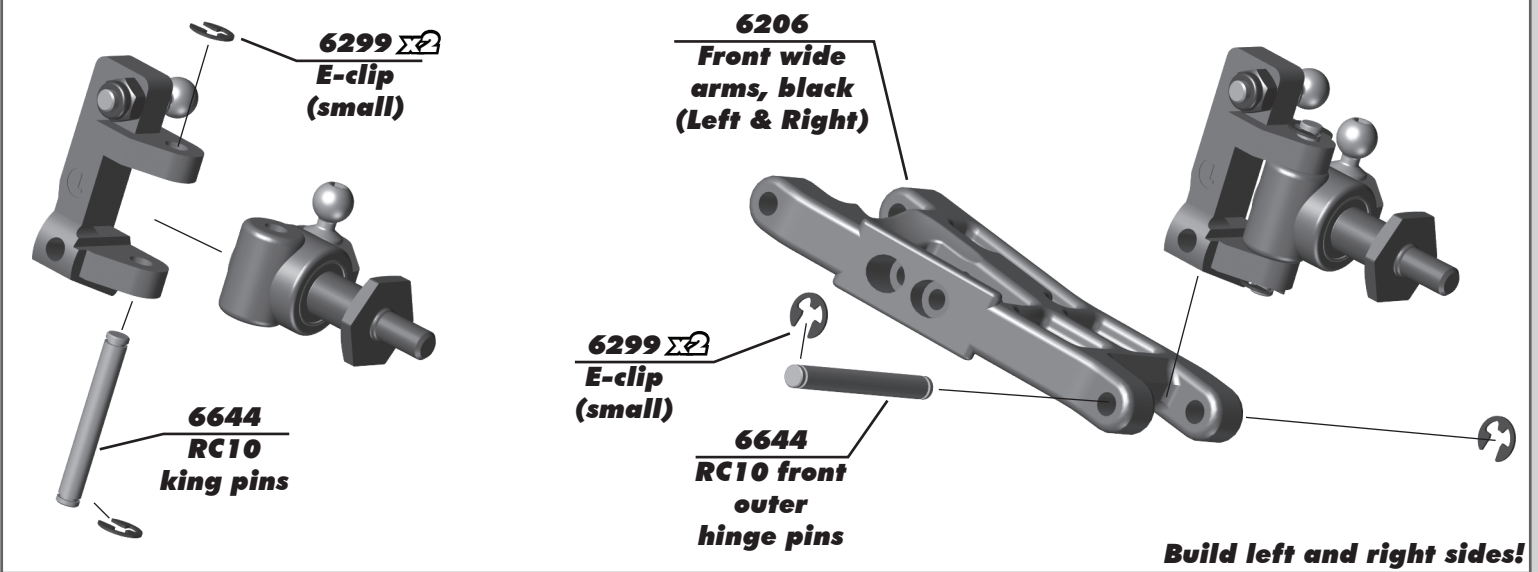

:: Front Suspension Build - Bag B - Step 3

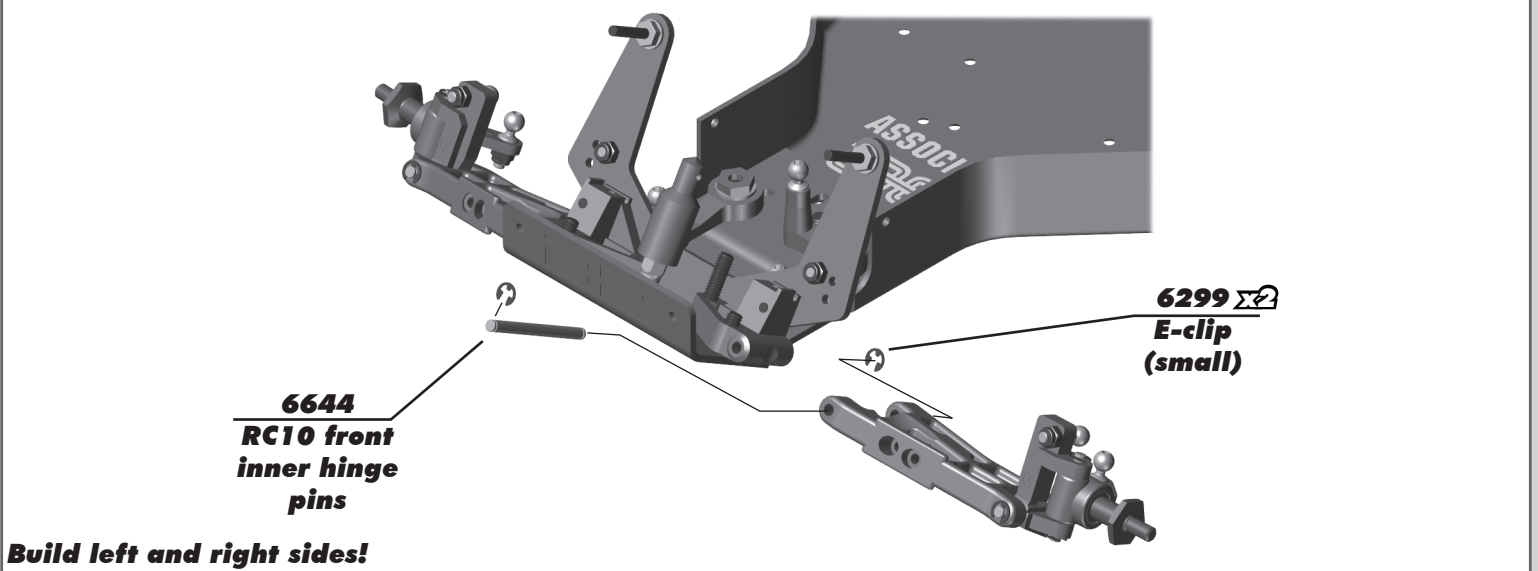

:: Rear Bulkhead Build - Bag C - Step 1

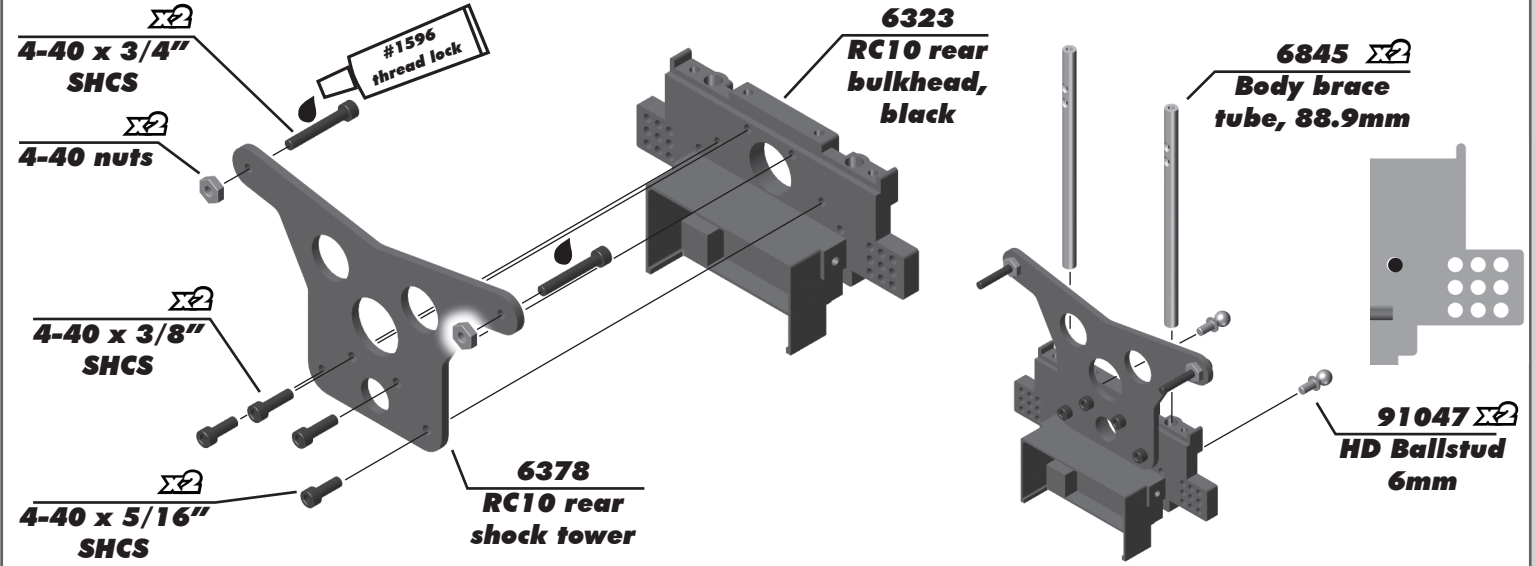

:: Rear Bulkhead Build - Bag C - Step 2

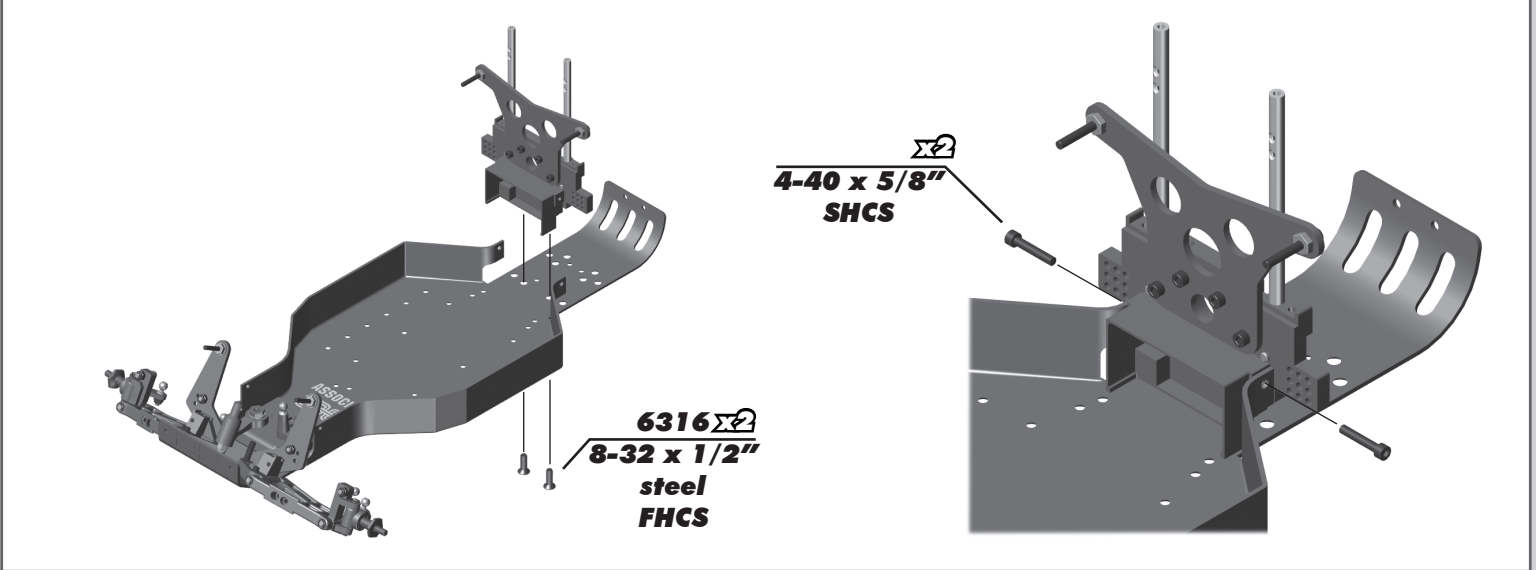

:: Transmission Build - Bag D - Step 1



The kit comes with both a diff locker and gear diff components. The diff locker is an optional part for tuning.

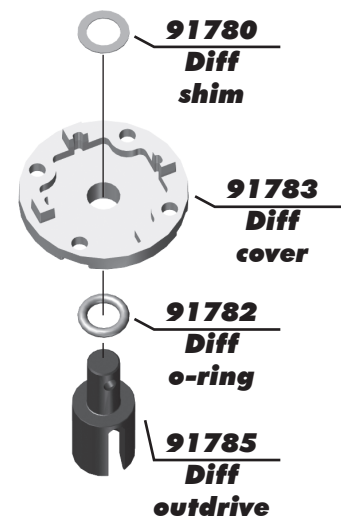
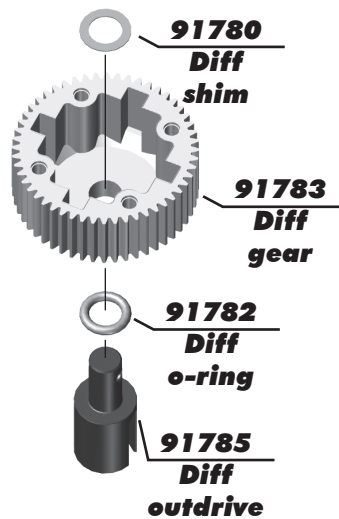

:: Transmission Build - Bag D - Step 2

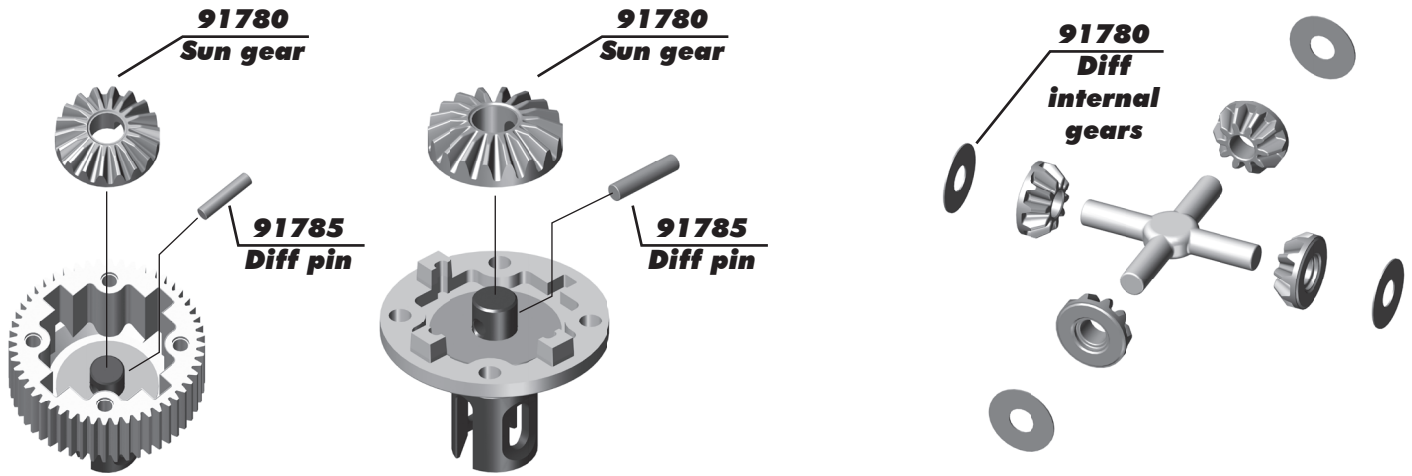

:: Transmission Build - Bag D - Step 3



:: Transmission Build - Bag D - Step 4 - OPTIONAL LOCKED DIFF BUILD

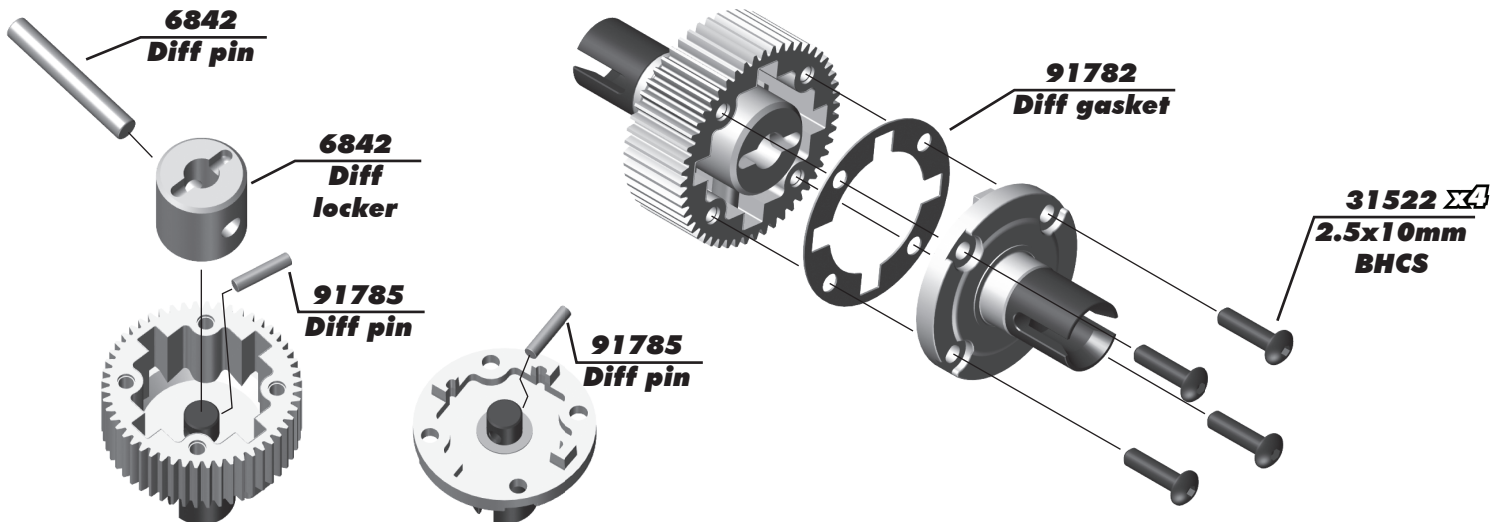

:: Transmission Build - Bag D - Step 5

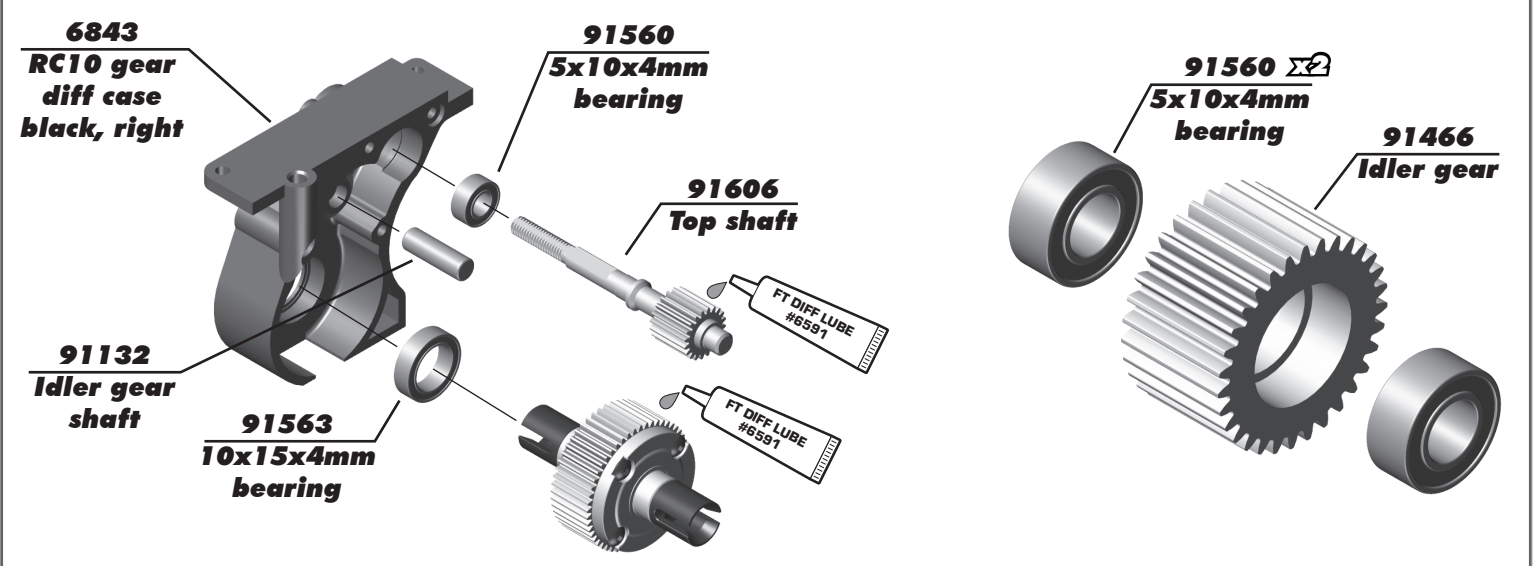

:: Transmission Build - Bag D - Step 6

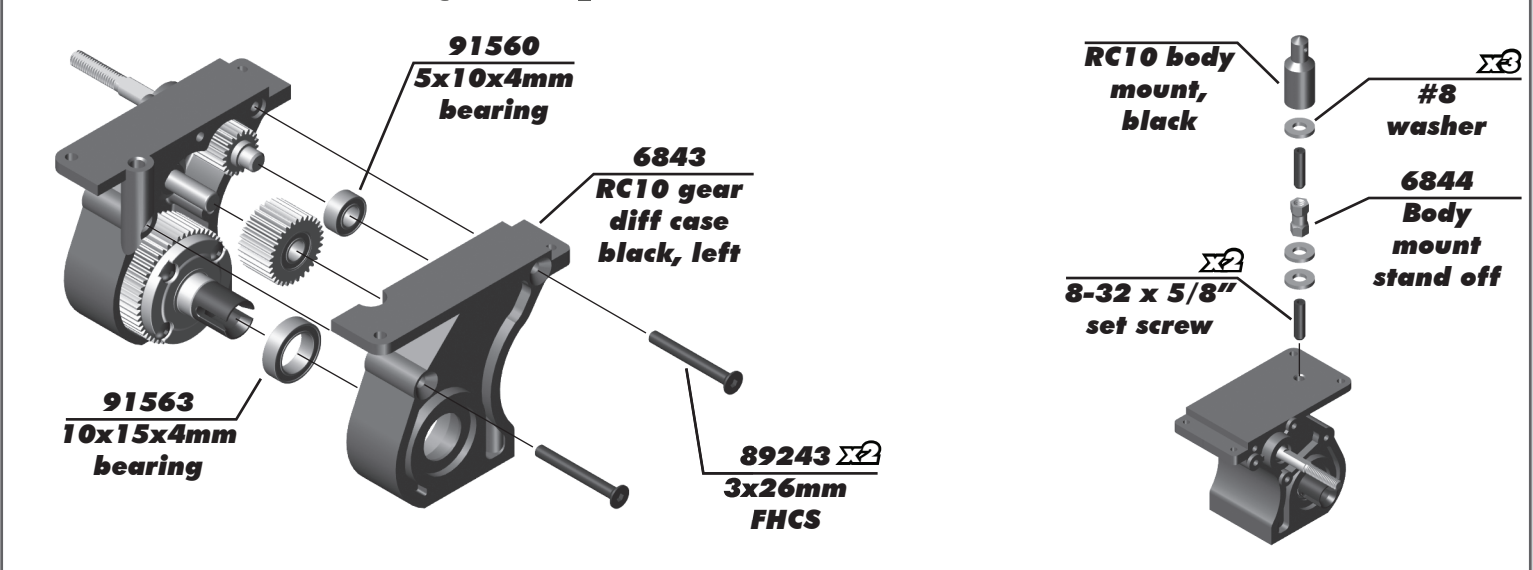

:: Transmission Build - Bag D - Step 7

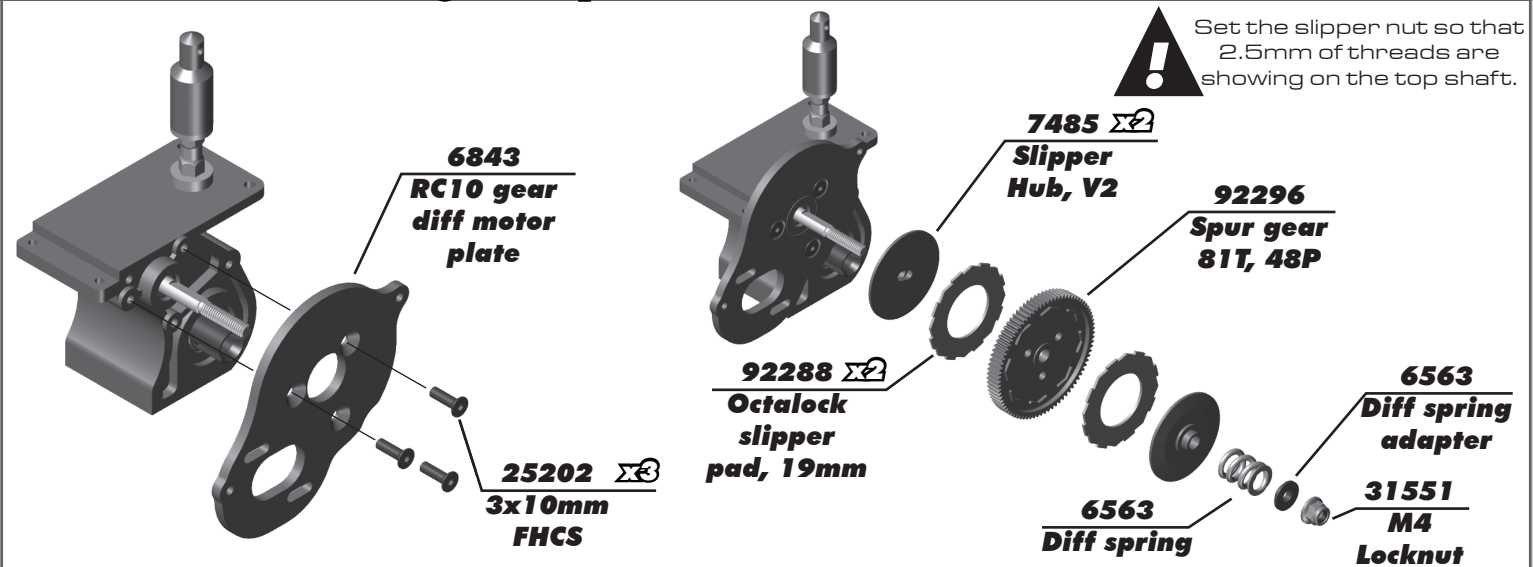

:: Transmission Build - Bag D - Step 8

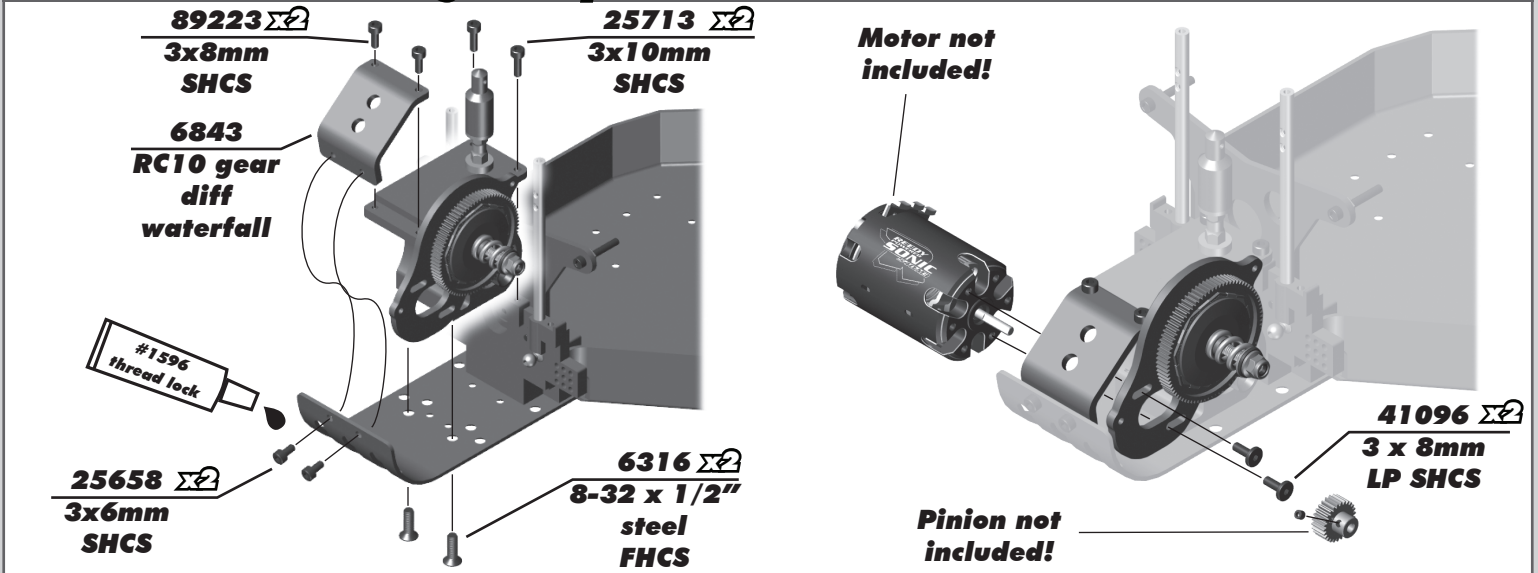

:: Rear Suspension Build - Bag E - Step 1

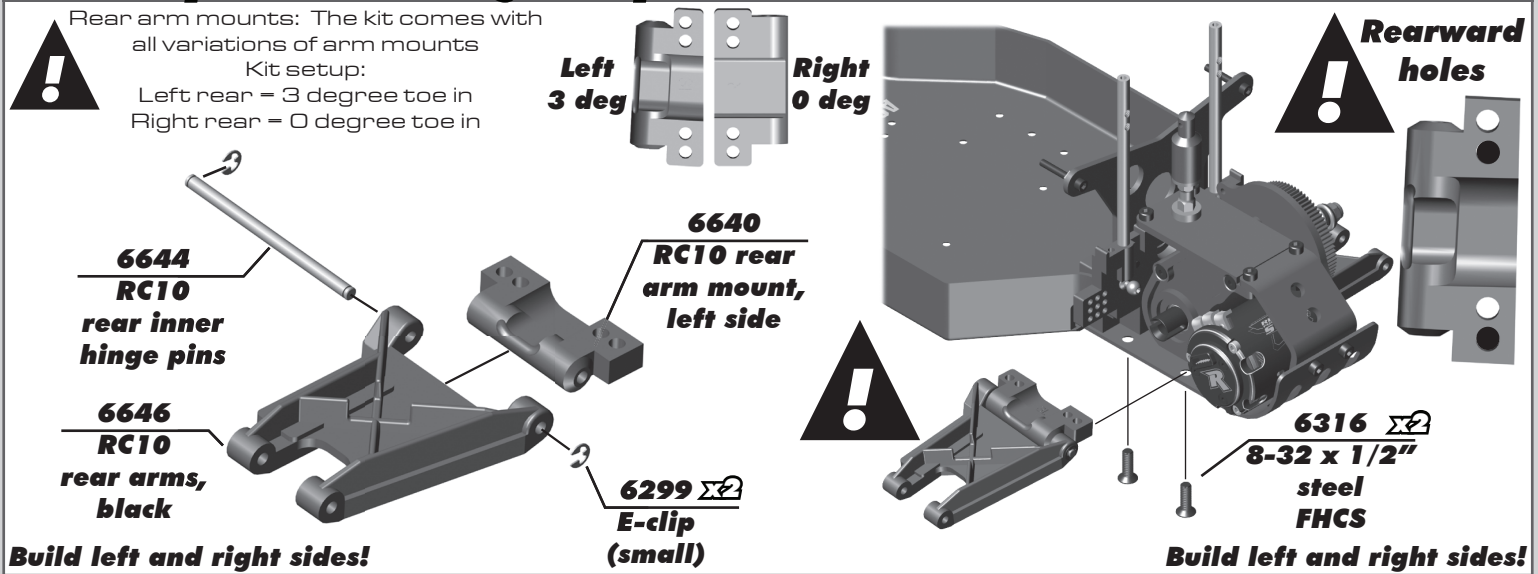

:: Rear Suspension Build - Bag E - Step 2

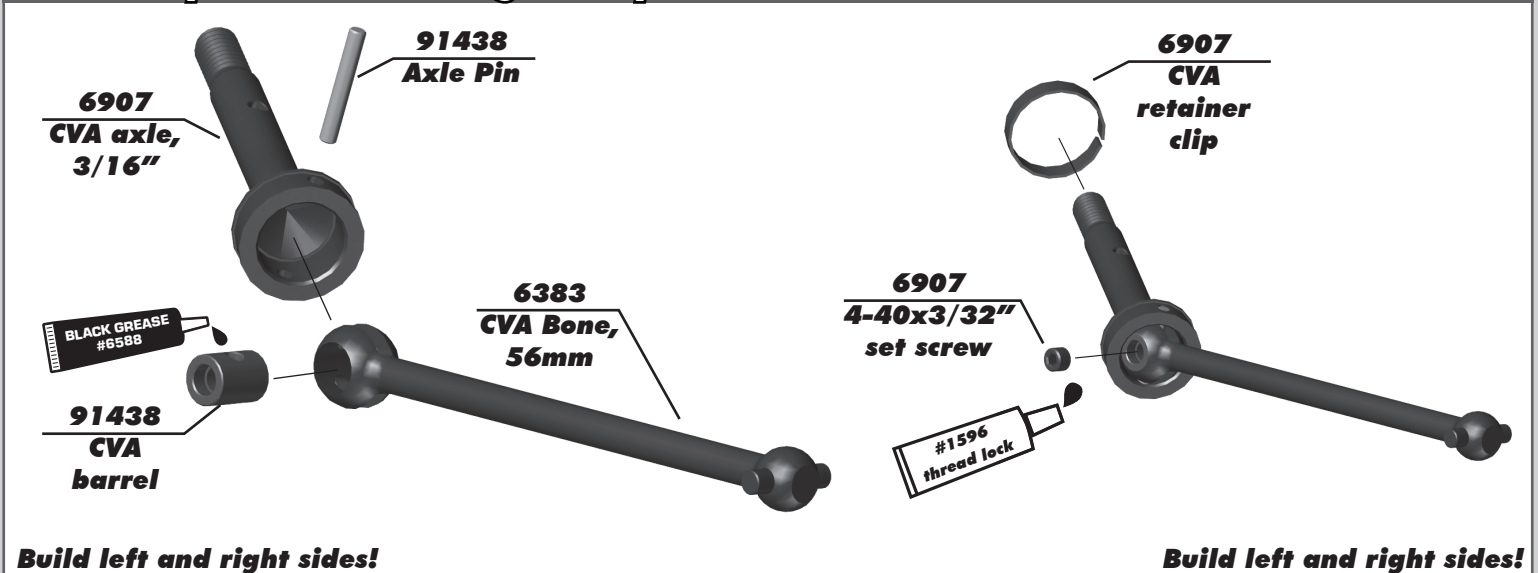

:: Rear Suspension Build - Bag E - Step 3



The kit comes with two different rear hubs. Kit setup:
 Left rear = 1.5 degree toe in
 Right rear = 0 degree toe in

Left side Right side



7370
RC10 rear hub carrier (1.5 deg) (left side)

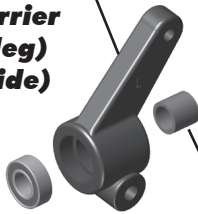

Crush tube

6371 $\Sigma 3$
Axle shims, 3/16"

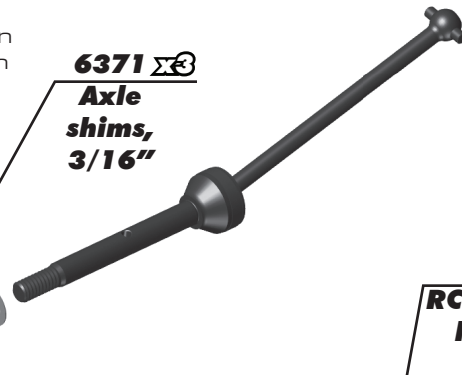

3977 $\Sigma 2$
Bearing 3/16" x 3/8" x 1/8"

6371
Roll pin

6907
RC10 12mm hex hub

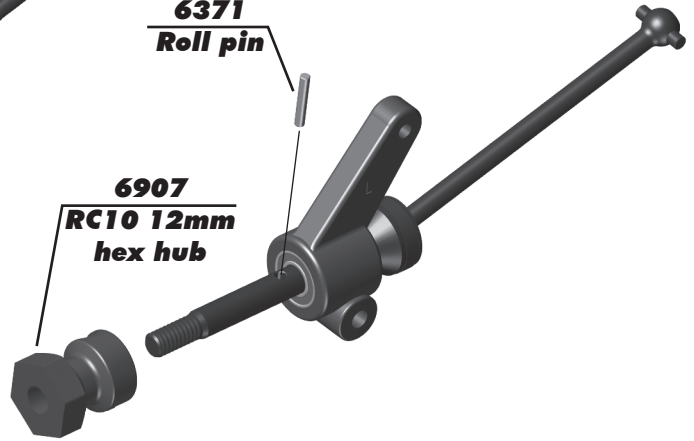

Build left and right sides!

:: Rear Suspension Build - Bag E - Step 4

91048
HD Ballstud 8mm



91611
1.6 x 5mm SHCS



25215
M3 locknut

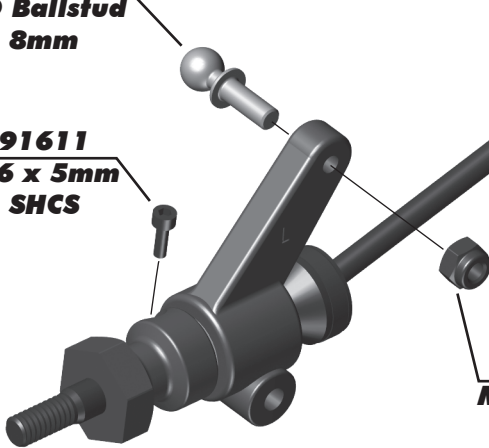

6644
RC10 rear outer hinge pins

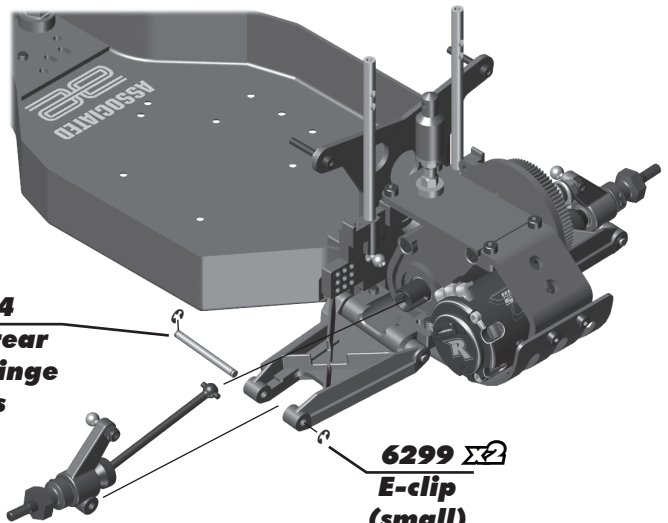

6299 $\Sigma 2$
E-clip (small)

Build left and right sides!

:: Turnbuckles Build - Bag F - Step 1

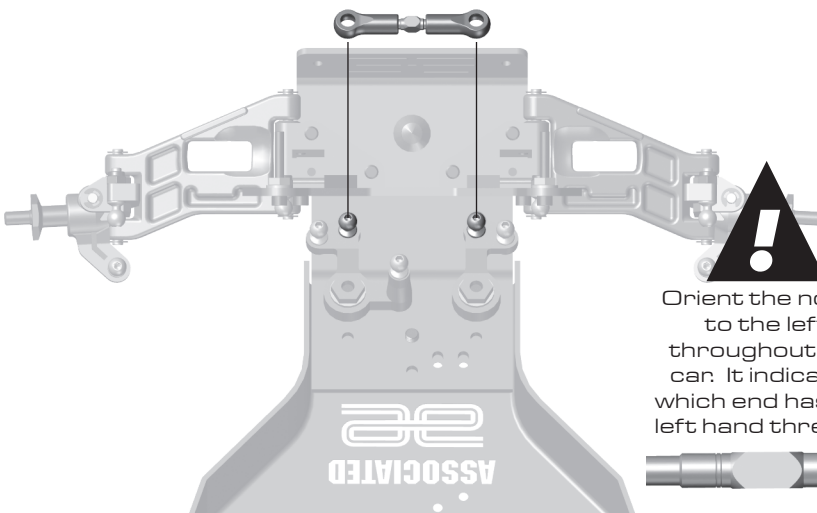

Orient the notch to the left throughout the car. It indicates which end has the left hand threads!

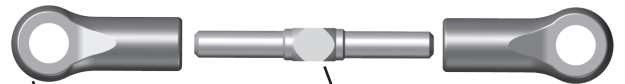

6535 $\Sigma 2$
Ball cups

6547
Steel turnbuckle, (3.5x27mm)

Steering Rack Turnbuckle 0.31" (8mm)

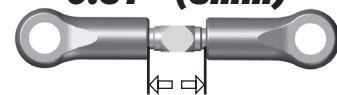

:: Turnbuckles Build - Bag F - Step 2

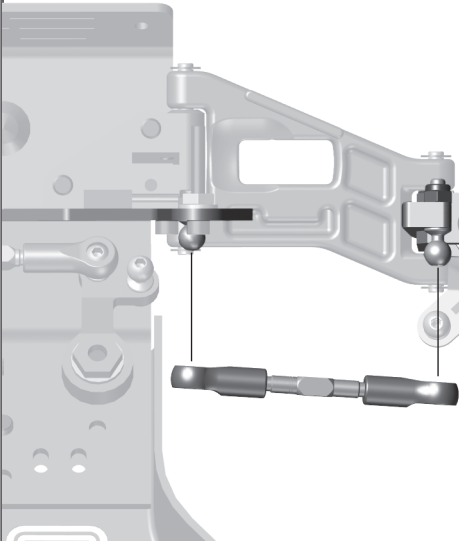

!
Orient the notch to the left throughout the car. It indicates which end has the left hand threads!

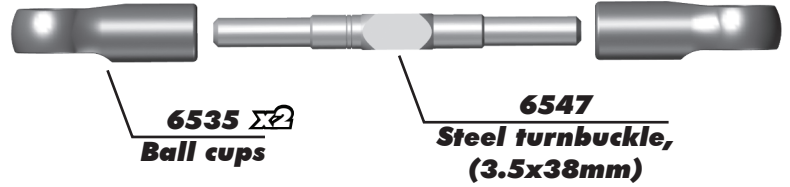

**Front Camber Turnbuckle
0.90" (23.00mm)**



Recommended turnbuckle lengths are approximate. Final recommended settings = 0 degree Front Toe in and -2 Degree Camber Front and Rear.

Build left and right sides!

:: Turnbuckles Build - Bag F - Step 3

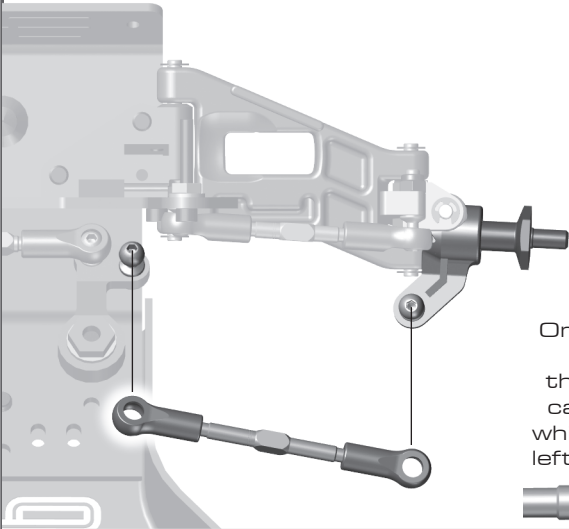

!
Orient the notch to the left throughout the car. It indicates which end has the left hand threads!

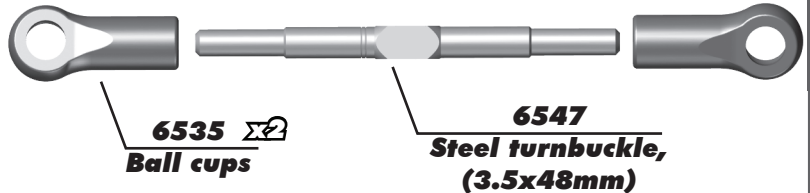

**Steering Turnbuckle
1.18" (30.00mm)**



Recommended turnbuckle lengths are approximate. Final recommended settings = 0 degree Front Toe in and -2 Degree Camber Front and Rear.

Build left and right sides!

:: Turnbuckles Build - Bag F - Step 4

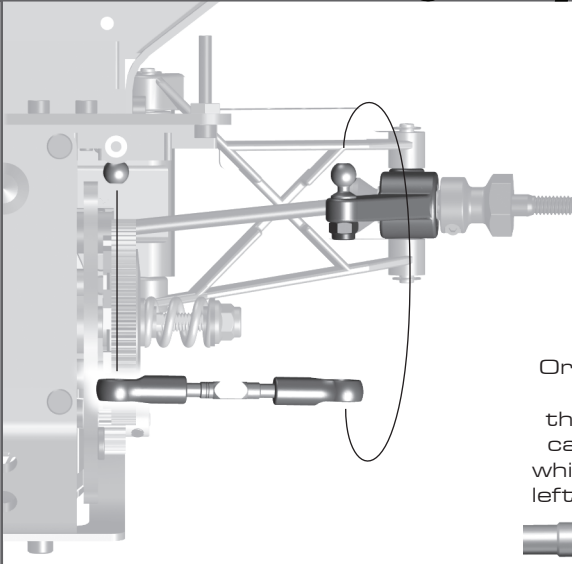

!
Orient the notch to the left throughout the car. It indicates which end has the left hand threads!

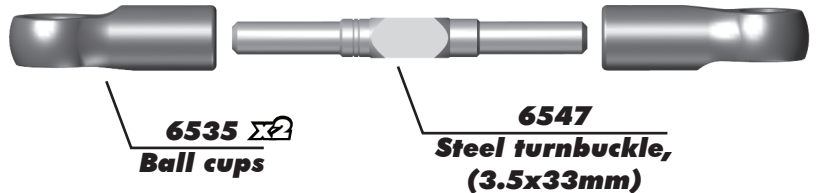

**Rear Camber Turnbuckle
0.75" (19mm)**

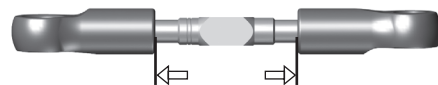

Recommended turnbuckle lengths are approximate. Final recommended settings = 0 degree Front Toe in and -2 Degree Camber Front and Rear.

Build left and right sides!

:: Shocks Build - Bag G - Step 1

Remove spurs

Piston

Piston number here
 Use #2 = front shocks
 Use #1 = rear shocks

TIP: Use marker to mark the piston numbers for easy identification!

6299 E-clip (small)

6462 Shock shaft, front (0.56)

6417 Shock shaft, rear (1.02)

6420/6462 Shock pistons (1, 2, 3)

6299 E-clip (small)

Build two front and two rear!

:: Shocks Build - Bag G - Step 2

5407 $\Sigma 2$ Red o-ring

Remove spurs

Shock assembly tool

6420/6462 $\Sigma 2$ Off-road shock rebuild kit

6462 FT Hard Anodized shock body, front (0.56)

6435 FT Hard Anodized shock body, rear (1.32)

Shock fluid 30wt #5422

SNAP!

SNAP!

Front Shock

Rear Shock

Place on table and push down hard until clamp snaps into place

:: Shocks Build - Bag G - Step 3

Front Shock

Rear Shock

6420/6462 $\Sigma 5$ Shock downstops

6420/6462 Shock cap o-ring

6420/6462 Shock rod end, short

6841 Shock pivot ball

Build two front and two rear!

:: Shocks Build - Bag G - Step 4

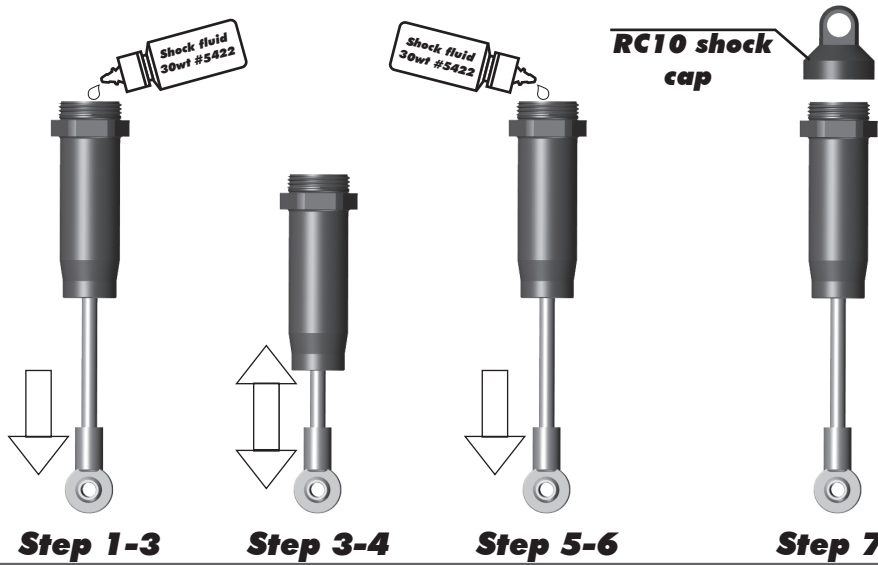

*** Shock Bleeding Steps:**

1. Pull shock shaft down.
2. Fill shock body 3/4 full with silicone fluid.
3. Slowly move the shock shaft up and down to remove air from under piston.
4. Wait for bubbles to come to surface.
5. Fill shock body to top with silicone fluid.
6. Place several drops of oil in the cap and on cap threads.
7. Install cap and tighten completely.
8. Slowly compress shaft all the way to the top. If there is pressure at the top of the stroke, there is too much oil. You must bleed it out.
9. Slowly pull shaft down.
10. Unscrew the cap 3/4 turn and tilt the shock at a slight angle.
11. Slowly compress the shaft to push out excess oil and air. You should see bubbles coming out from under the cap.
12. With the shaft compressed, tighten the cap and re-check for pressure at the top of the stroke. If there is still pressure, repeat steps 9 thru 11.

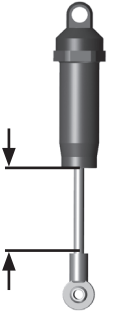

Stroke
Front:
16mm
Rear:
21mm

:: Shocks Build - Bag G - Step 5

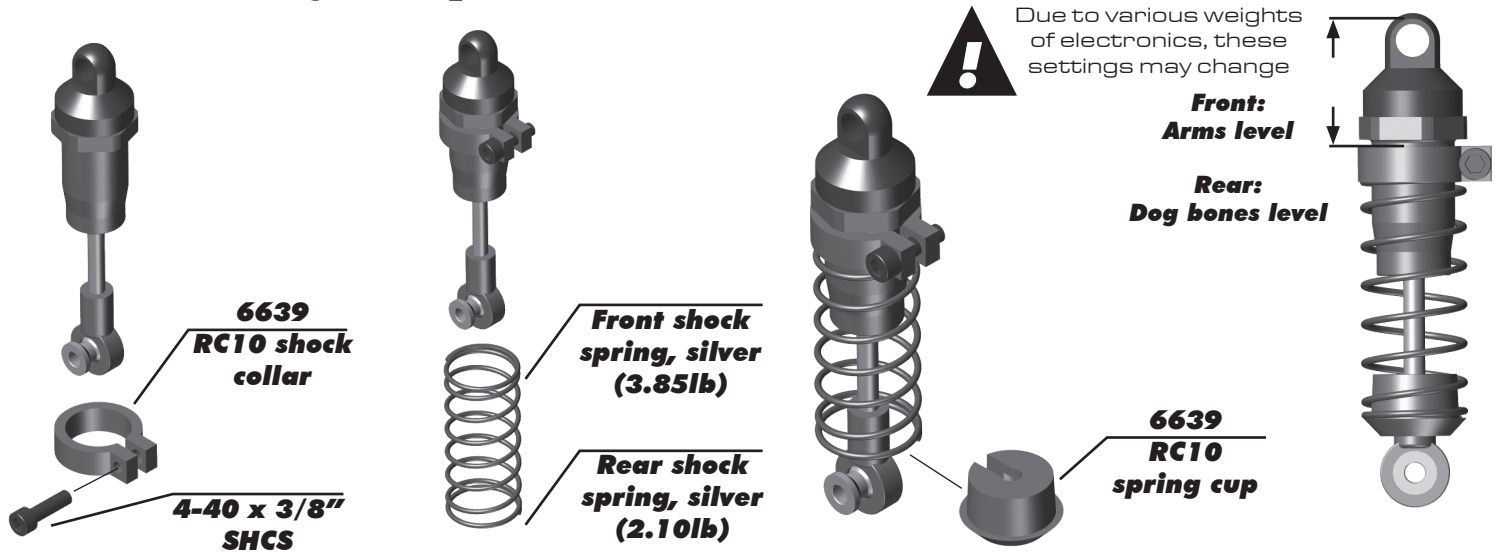

:: Shocks Build - Bag G - Step 6

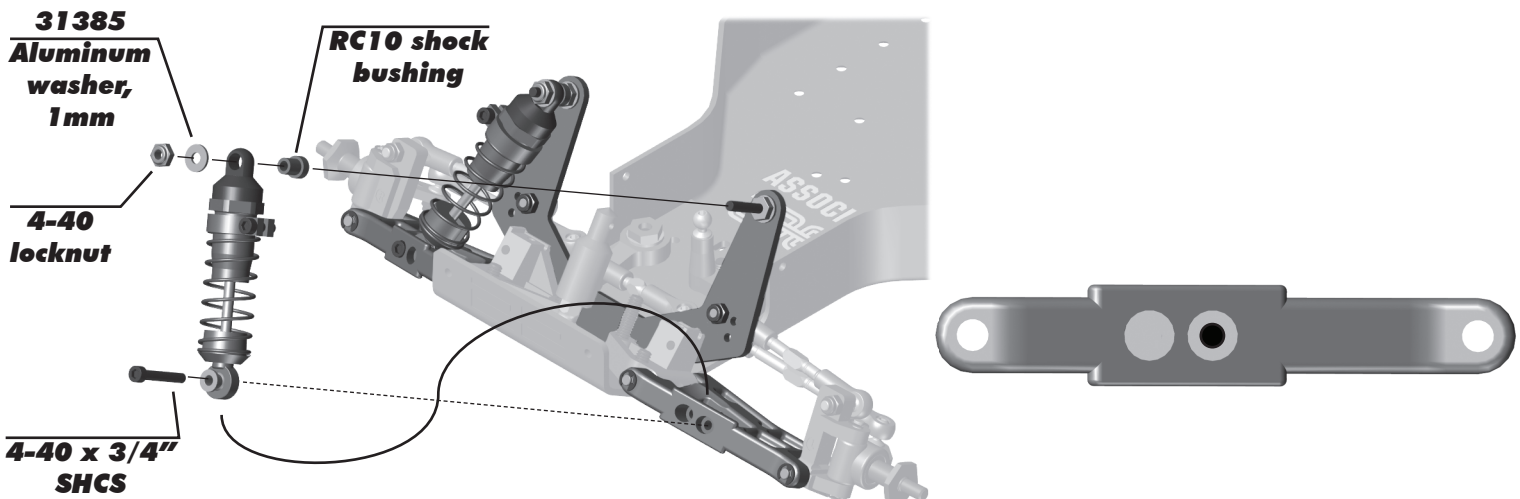

Build left and right sides!

:: Shocks Build - Bag G - Step 7

**RC10 shock
bushing**

**31385
Aluminum
washer,
1mm**

**4-40
locknut**

**4-40 x 3/4"
SHCS**

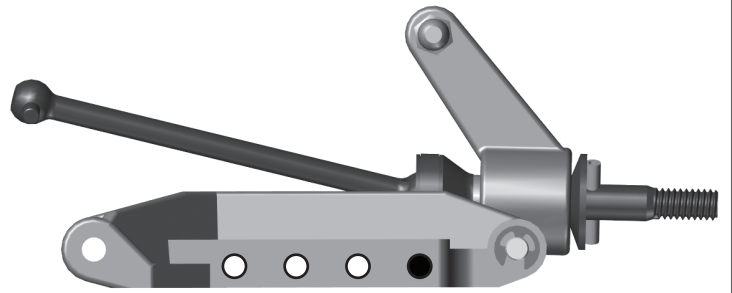
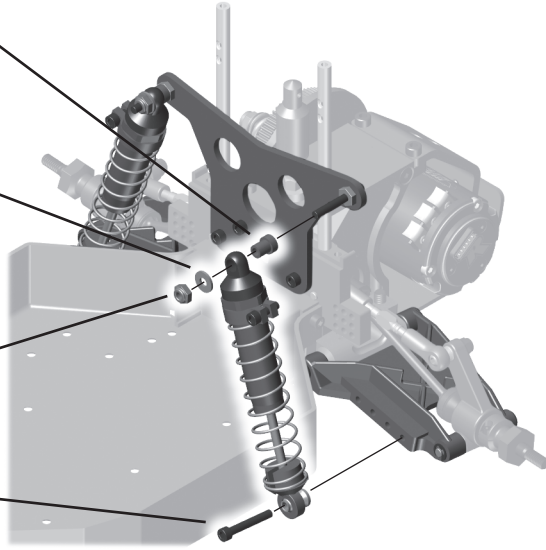

Build left and right sides!

:: Electronics Build - Bag H - Step 1

**6638
RC10 nose
brace tubes**

2
**4-40 x 3/8"
BHCS**

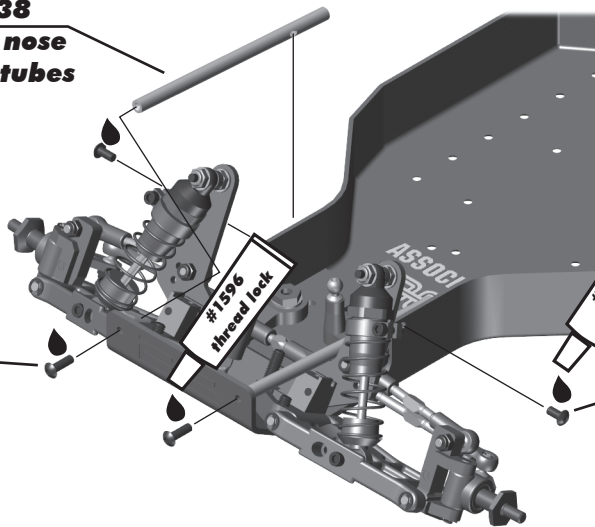

1
**4-40 x 3/8"
BHCS**

Build left and right sides!

:: Electronics Build - Bag H - Step 2

**6846 $\Sigma 2$
Sprint car
wing mount
set**

**31385 $\Sigma 2$
Aluminum
washer,
1mm**

**6846
Sprint car
wing mount,
front**

**4-40 x 1/4"
FHCS**

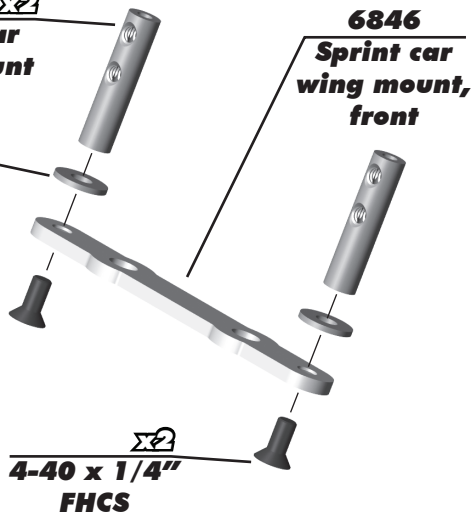

**8-32 x 1/4"
BHCS**

**6846 $\Sigma 2$
Sprint car
wing mount,
front**

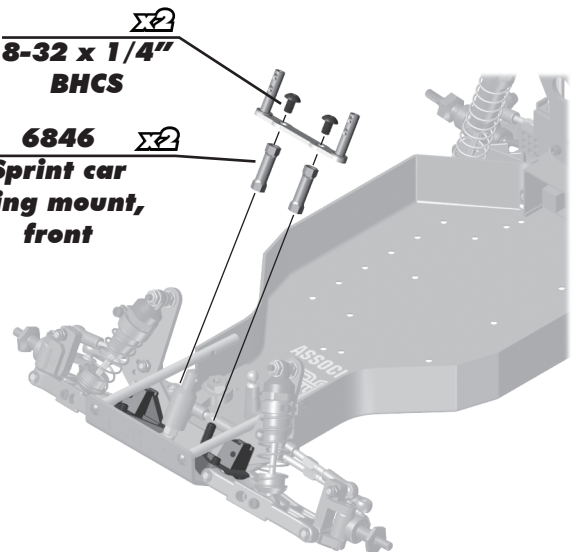

:: Electronics Build - Bag H - Step 3

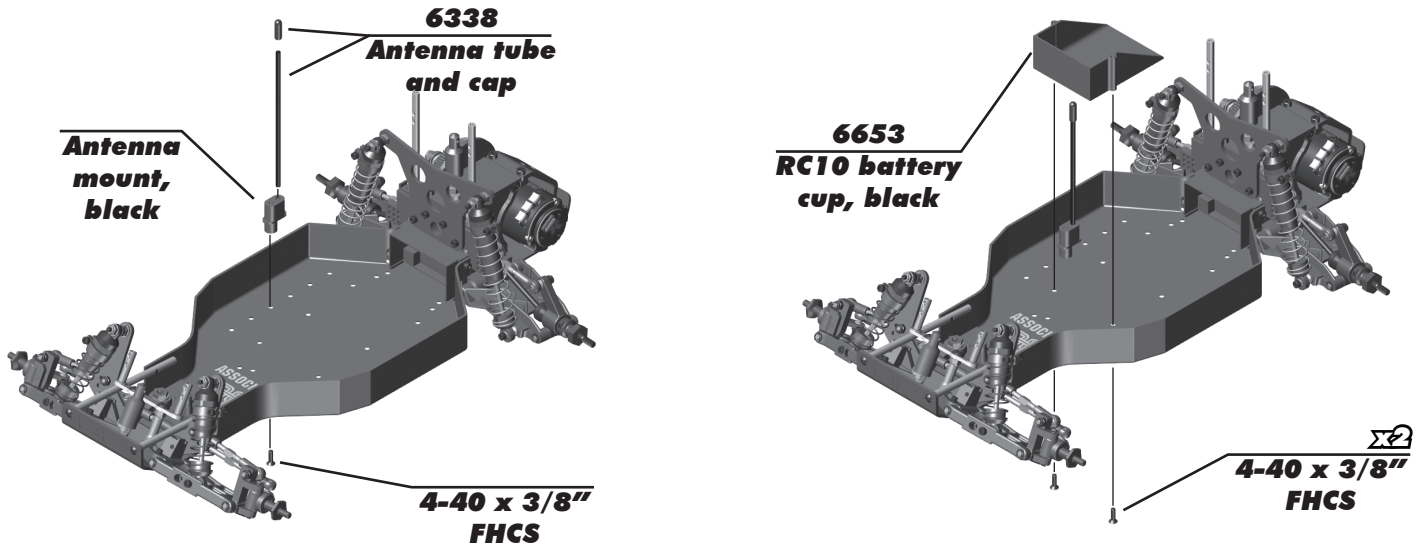

:: Electronics Build - Bag H - Step 4

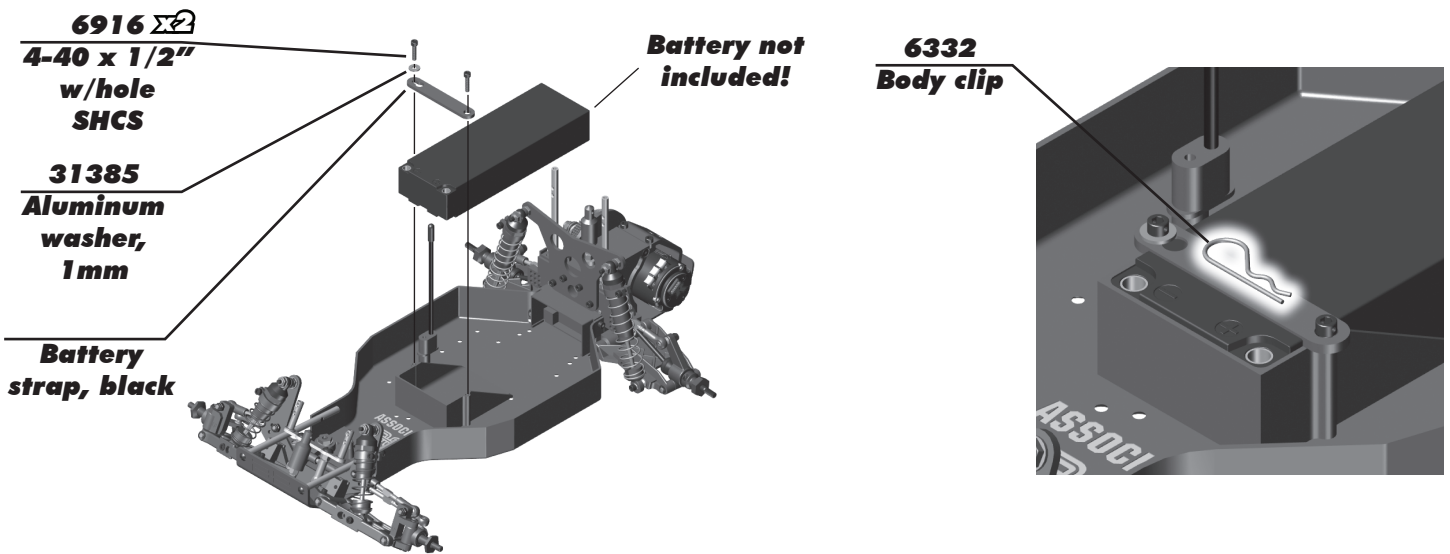

:: Electronics Build - Bag H - Step 5

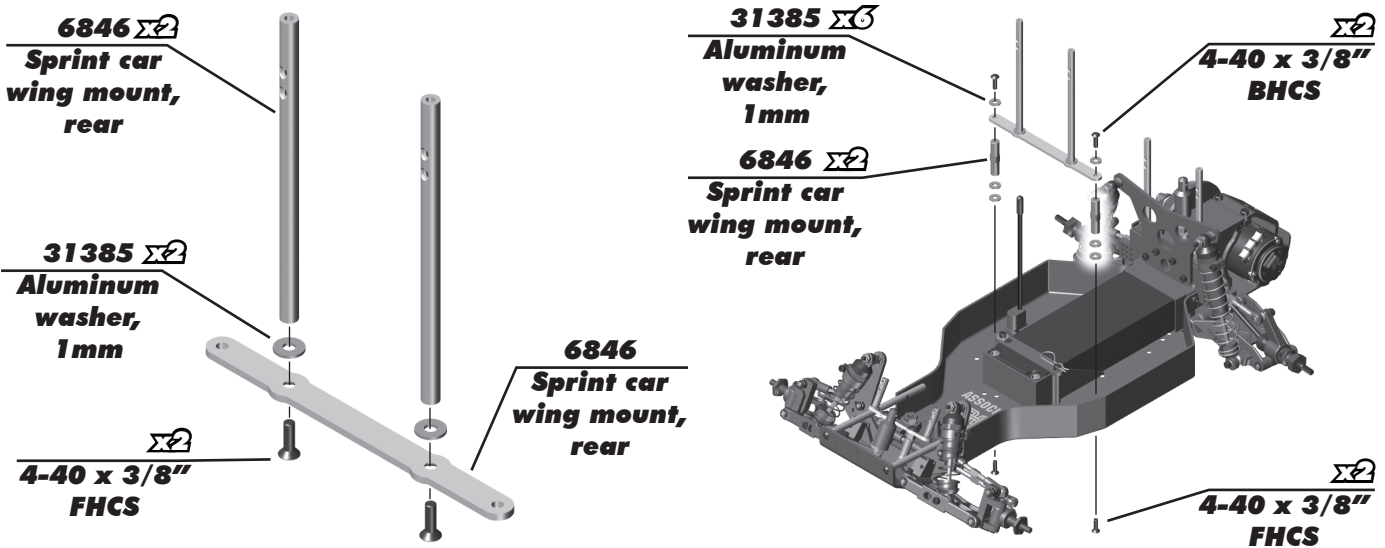

:: Servo Build - Bag I - Step 1

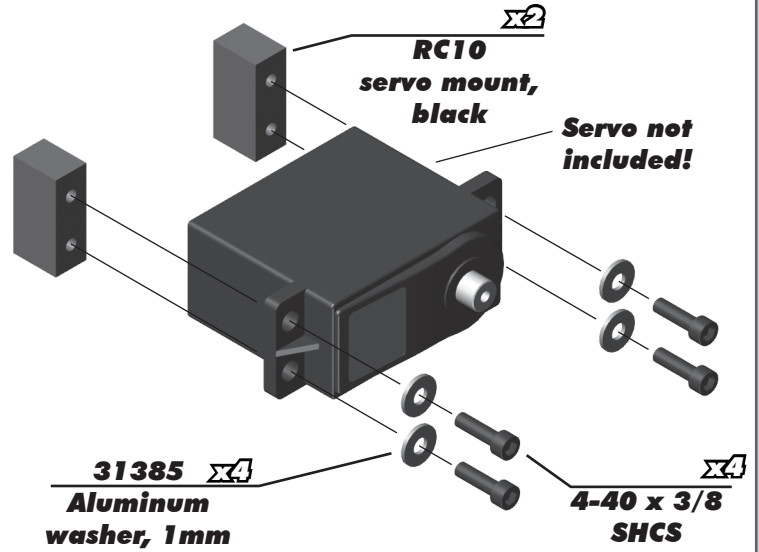
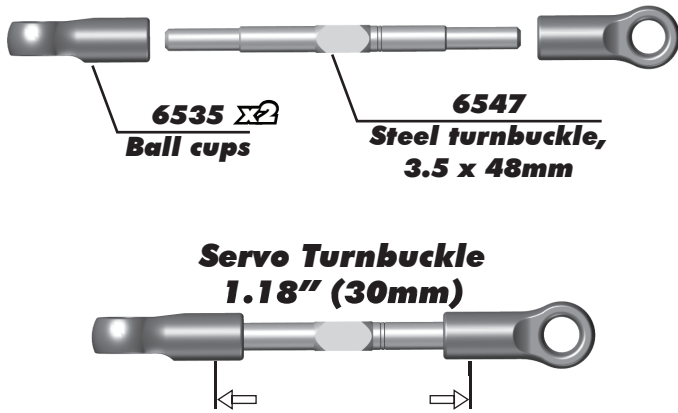

:: Servo Build - Bag I - Step 2

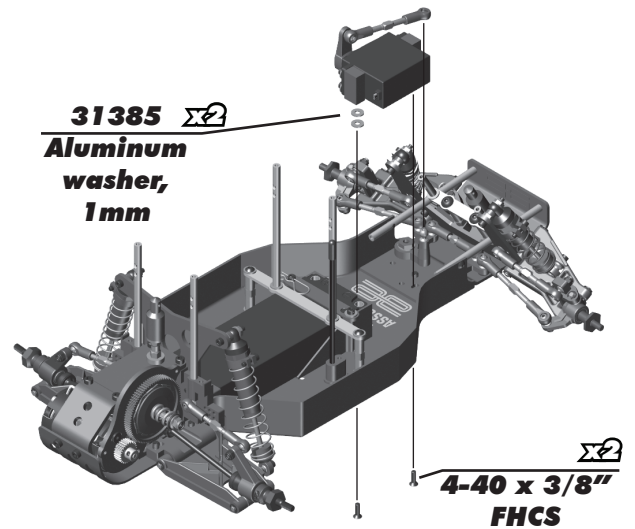
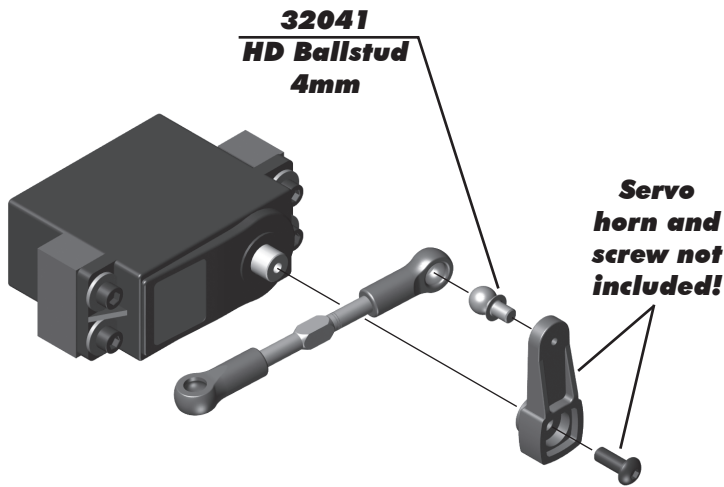

:: Wheels / Tires and Body - Bag J - Step 1

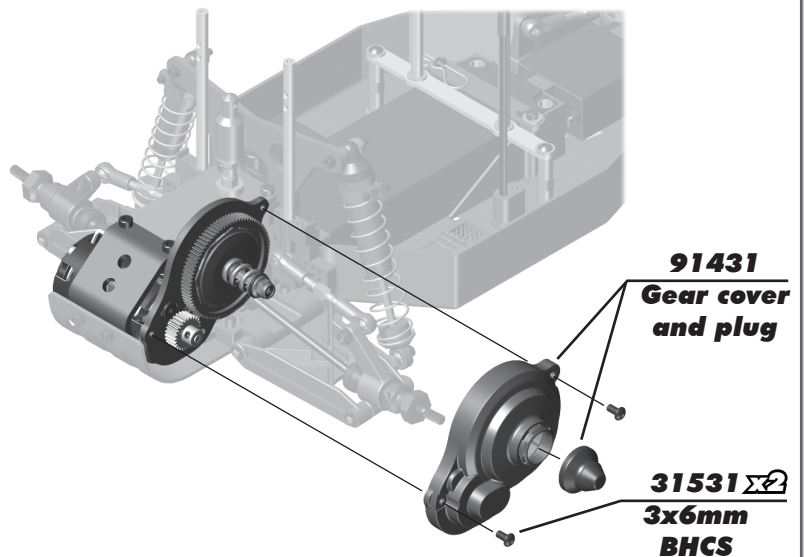
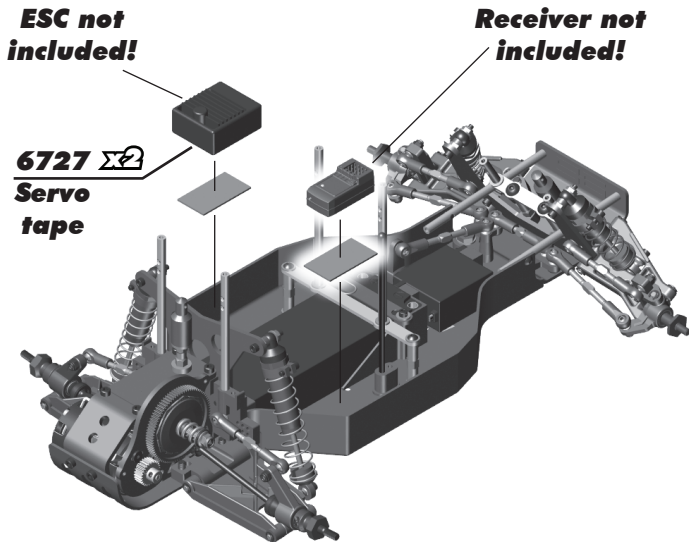

:: Wheels / Tires and Body - Bag J - Step 2

Build 2

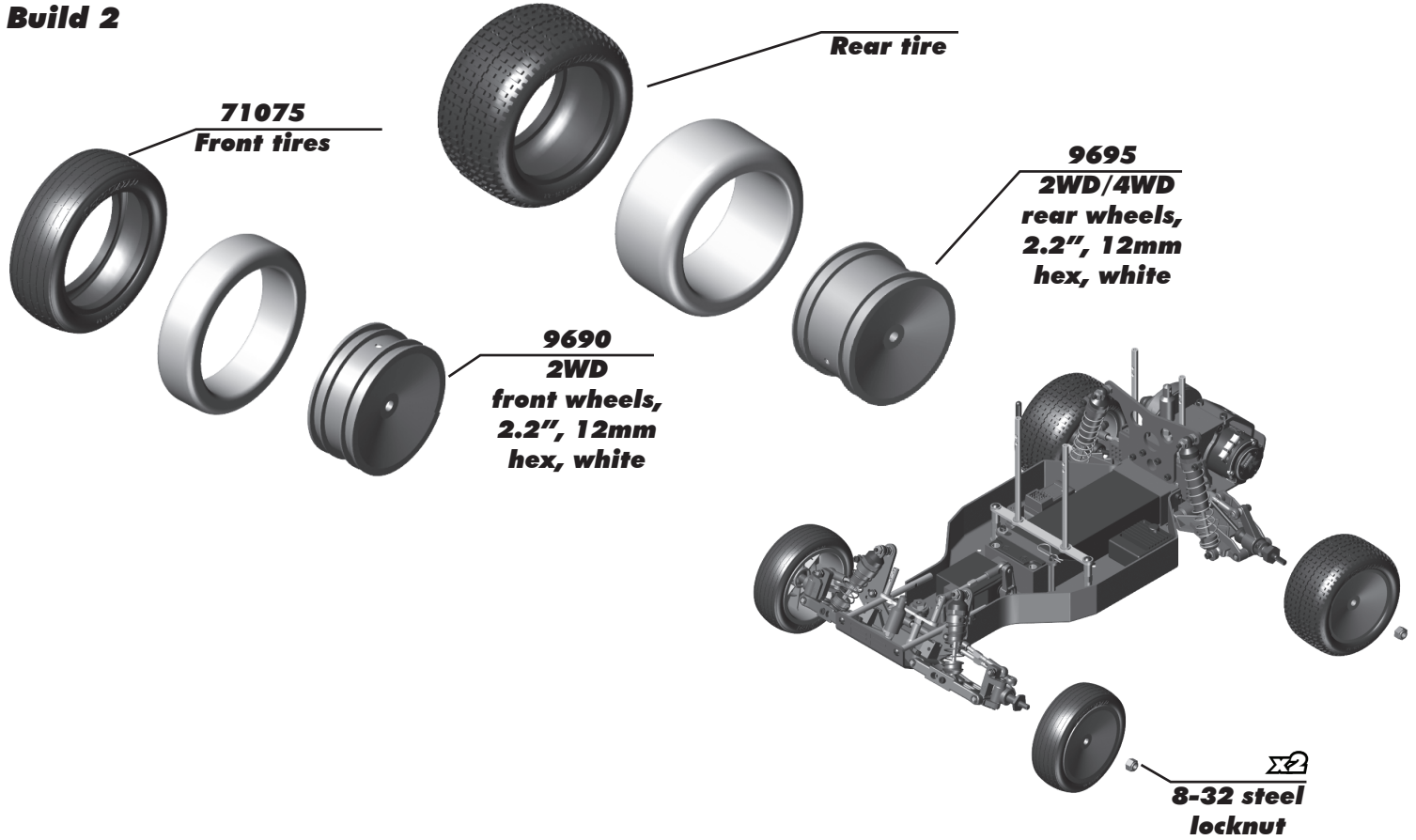

:: Wheels / Tires and Body - Bag J - Step 3

Painting Tips:

Your RC10 Kit comes with a clear polycarbonate body and wing. You will need to prep the body and wing before you can paint them. Wash the inside thoroughly with warm water and liquid detergent. Dry the body and wing using a clean, soft, lint-free cloth. Use high quality masking tape to make masks for the windows and install them on the inside of the body (RC cars get painted from the inside). Using high quality masking tape, apply tape to the inside of the body to create a design. Spray (either rattle can or airbrush R/C specific paint) the paint to the inside of the body (preferably dark colors first, lighter colors last).

NOTE: use ONLY paint that is recommended for use with [polycarbonate] plastics. If you do not, you can destroy the plastic body and wing!!!!). It is recommended to wear a mask while painting.

After the paint has dried, cut the body and wing along the trim lines. Make sure to drill or use a body reamer to make the holes for the body mounts, wing mounts, and antenna!

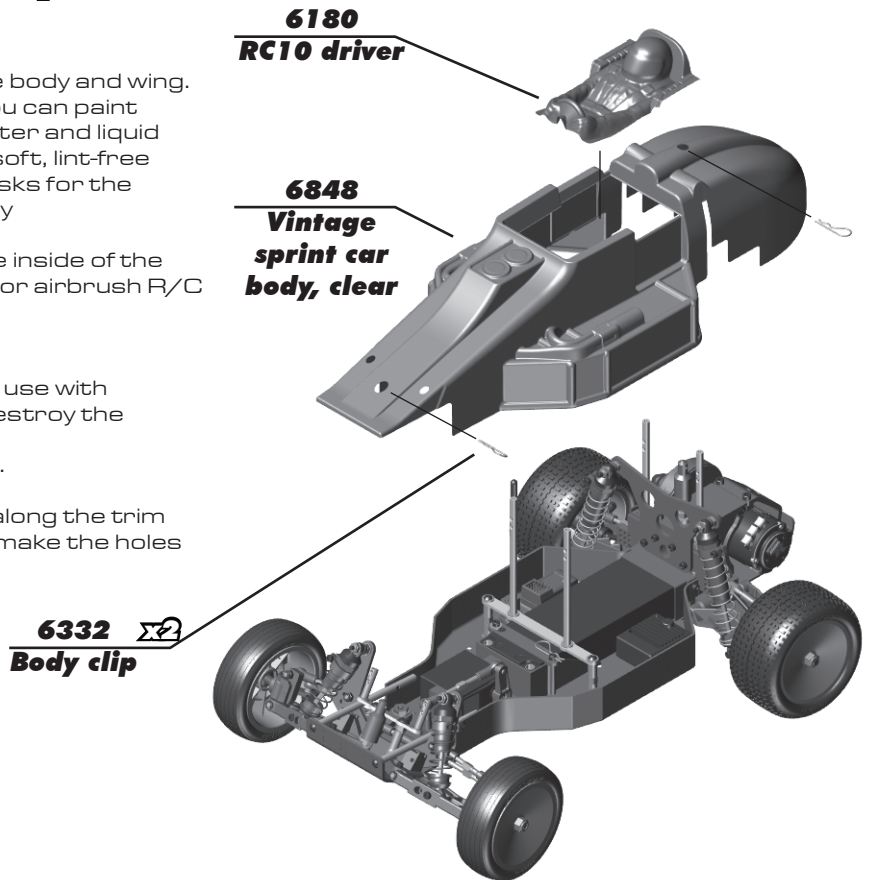

:: Wheels / Tires and Body - Bag J - Step 4

6847 **X2**
Wing wire
mount set

6648
Wing mount
wire, front



Cut the wing wire
down to 18mm of
usable wire for the
front wing tubes.

6849
Sprint car
wing set

X2
4-40 x 1/8"
set screw

X4
4-40 x 1/8"
set screw

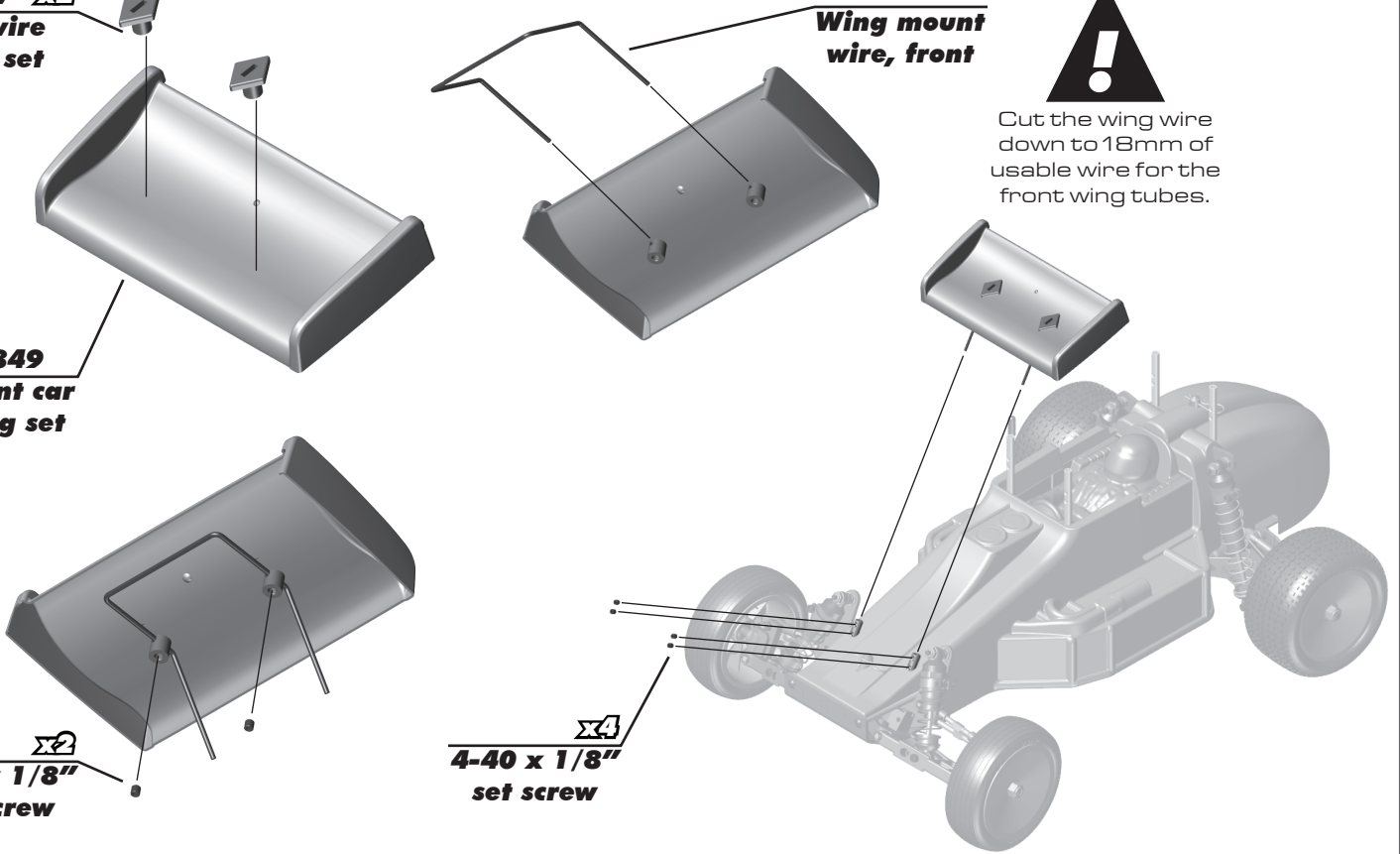

:: Wheels / Tires and Body - Bag J - Step 5

6847 **X4**
Wing wire
mount set



Racer Tip:

Trim down the
Main wing wire
10mm shorter for
a lower main wing.

6849
Sprint car
wing set

6847 **X2**
Wing wire
mount set

X4
4-40 x 1/8"
set screw

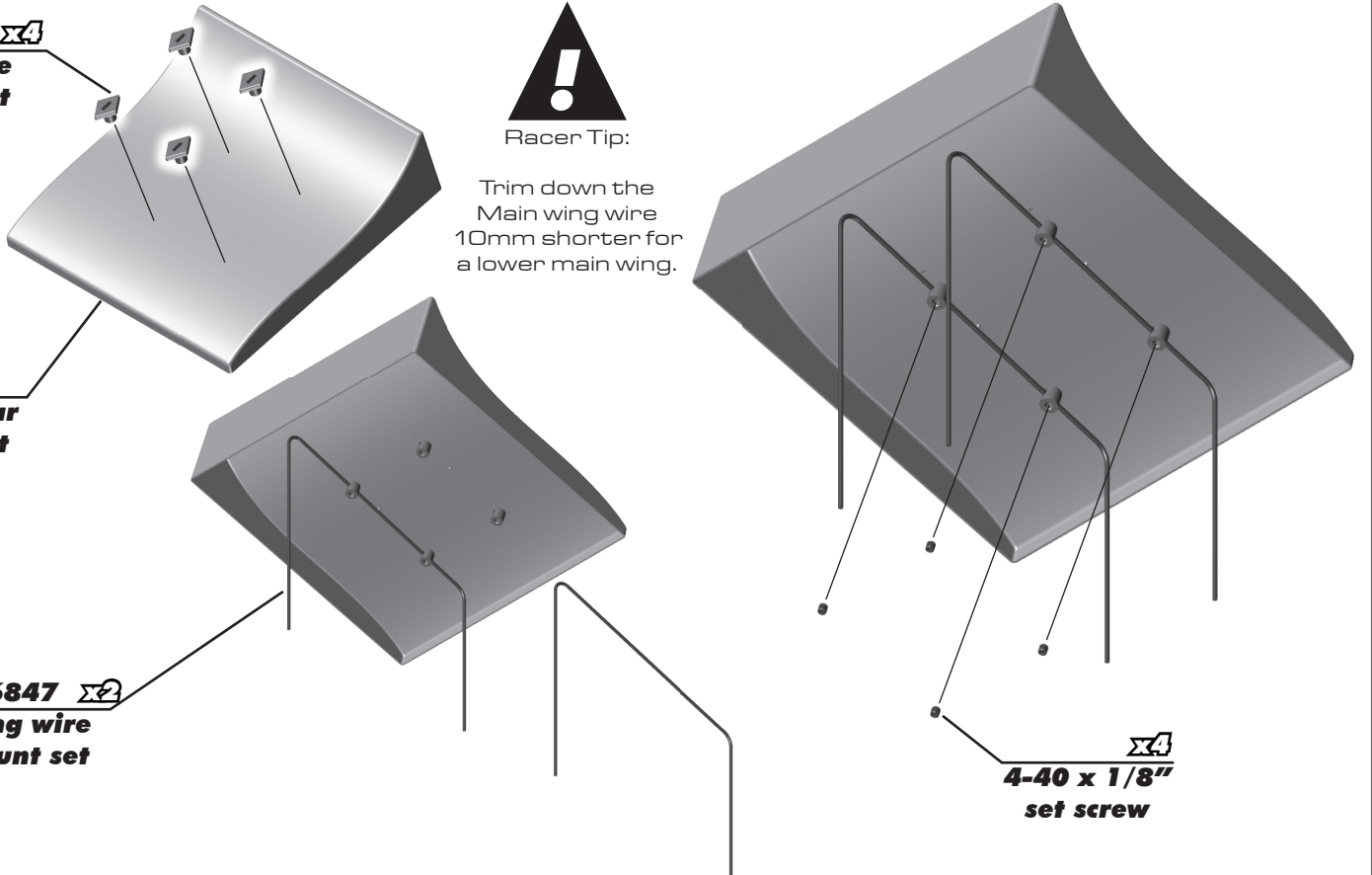

:: Wheels / Tires and Body - Bag J - Step 6

6849 x10
4-40 x 1/4"
BHCS

6849
Sprint car
wing set

6242 x10
4-40
locknut,
steel

6849
Sprint car
wing set

x3
4-40 x 1/8"
set screw

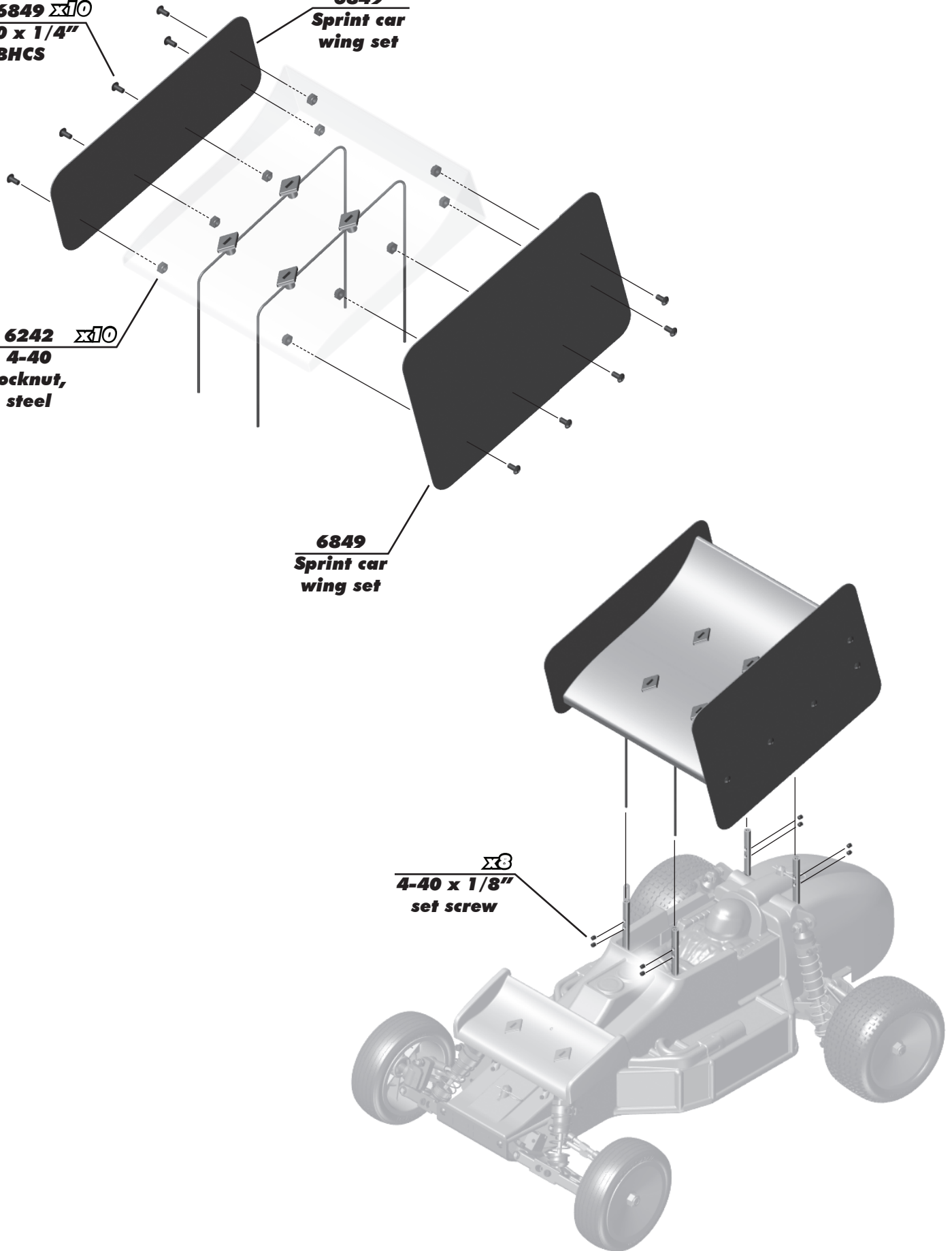

:: Notes

Blank area for notes.



Associated Electrics, Inc.
21062 Bake Parkway Lake Forest, CA 92630 USA

call: (949) 544-7500 - fax: (949) 544-7501
Check out the following web sites for all of our kits, current products,
new releases, setup help, tips, and racing info!
www.AssociatedElectrics.com

FOLLOW US ON SOCIAL MEDIA



TeamAssociated
ReedyPower
ElementRC
FactoryTeam51



@TeamAssociatedRC
@ReedyPower
@Element_RC
@FactoryTeam_RC



@Team_Associated
@ReedyPower



@Associated_Electrics



TeamAssociatedRC
ElementRC



TeamAssociated
Reedy
Element-rc