

RESET

Front Suspension:

Ride Height: 24 mm
Camber: N/A
Toe: +2* (Tierod Gap = 22.5 mm)
Anti-Roll Bar
Size: 2.3 mm (Black)
Gap: 2 mm
Ackerman
Notes: #81063 FT Steering Block Arm +2 Deg, Aluminum
Drive Shaft: CVAs: <input checked="" type="checkbox"/> Universals: <input type="checkbox"/>
Chassis Brace: Short: <input checked="" type="checkbox"/> Long: <input type="checkbox"/>
Hex: #81079 Wheel Hex, 1 mm
Notes: #81092 FT Aluminum Steering Bellcrank Posts #81085 FT Servo Saver Arm, Aluminum

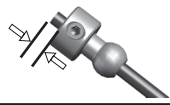

Caster Shim: 2 mm F / 2 mm R
Upper Ball Type: #81067 Steel
Upper Ball Shim: 0
Washers: 0
Lower Ball Shim: 0

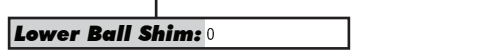
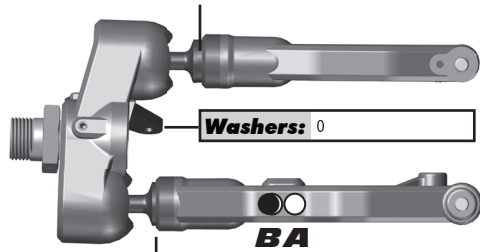
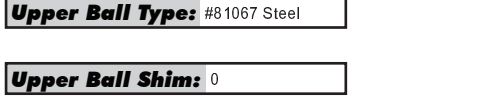
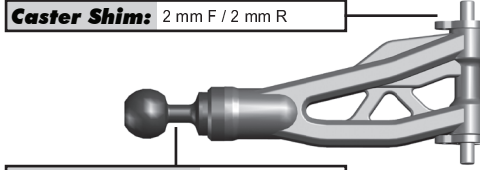

Wheelbase Shim: 1 mm R / 0 mm F
--

Lower Ball Type: #81067 Steel

Upper Arm Mount:

Arm Mount A:

Arm Mount B:

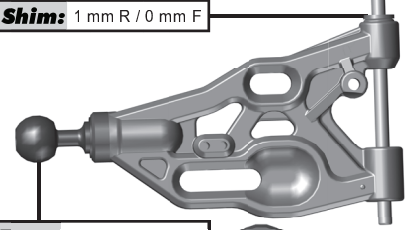

Rear Suspension:

Ride Height: 28 mm
Camber: -1 (Tierod Gap = 15.5 mm)
Anti-Roll Bar
Size: 2.7 mm (Blue)
Gap: 2 mm (Ball Reversed)
Drive Shaft: CVAs: <input checked="" type="checkbox"/> Universals: <input type="checkbox"/>
Chassis Brace: Short: <input type="checkbox"/> Long: <input checked="" type="checkbox"/>
Hex: #81079 Wheel Hex, 1 mm
Notes: FastRace +5 mm Shock Standoffs

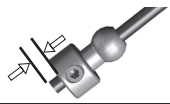

Hub Shim: 2.5 mm F / 2.5 mm R

Wheelbase Shim: 1 mm

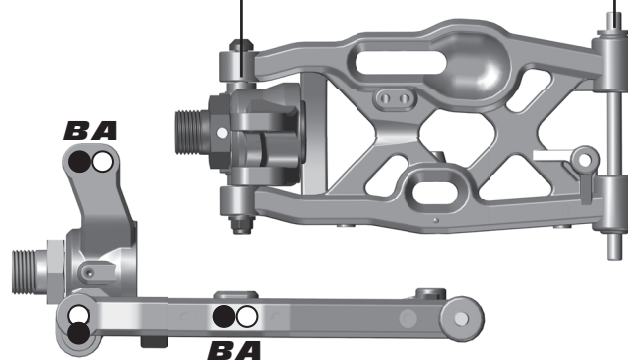

Arm Mount C:

Arm Mount D:

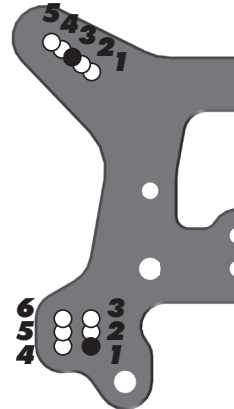

Electronics and Engine:

Radio: Sanwa M12
Receiver Battery: #315 Reedy 2100 mAh
Throttle Servo: #27106 Reedy RS1806A
Steering Servo: #27106 Reedy RS1806A (20 mm Servo Horn)
EPA: Throttle: 42 % Brake: 57 %
Brake Bias: 50% F / 50% R D/R: 100 %
Engine: FX K301 Temp: N/A
Muffler: 2108 Fuel: Sigma
Restrictor: 6 mm Glow Plug: FX X4
Notes:

Differential:

	Fluid	Gear Set	Planet O-Rings
Front:	6,000	HTC	0
Center:	7,000	HTC	0
Rear:	3,000	HTC	0

Clutch and Gearing:

Spur Gear: 46	Bell: 13
Shoes: 2 x #81377 Composite + 2 x #81375 Aluminum	
Springs: 2 x 0.95 (Green) + 2 x 1.05 (Silver)	
Notes:	

Shocks:

	Front	Rear
Piston:	8 x 1.2 Tapered	8 x 1.3 Tapered
Fluid:	42.5 wt	40 wt
Cap:	FastRace	FastRace
Rebound:	10 mm	10 mm
Spring:	Green V2	White V2
Free Length:	105 mm	120.5 mm
Notes:	#81174 & #81175 FT Chrome Shock Shafts; #81164 & #81165 Fox Shock Bodies; #81407 FT Shock Seal Bushing	
Set		

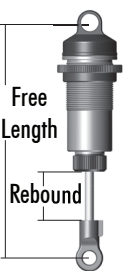

Track Info:

Size: Small <input type="checkbox"/> Medium <input checked="" type="checkbox"/> Large <input type="checkbox"/> Extra Large <input type="checkbox"/>
Surface: Dirt <input checked="" type="checkbox"/> Carpet <input type="checkbox"/> AstroTurf <input type="checkbox"/> Multi Surface <input type="checkbox"/>
Traction: Low <input type="checkbox"/> Medium <input type="checkbox"/> High <input checked="" type="checkbox"/> Very High <input type="checkbox"/>
Moisture: Dry <input checked="" type="checkbox"/> Damp <input type="checkbox"/> Wet <input type="checkbox"/>
Condition: Indoor <input type="checkbox"/> Outdoor <input checked="" type="checkbox"/> Dusty <input type="checkbox"/> Hard Packed <input checked="" type="checkbox"/> Bumpy <input checked="" type="checkbox"/> Grooved <input checked="" type="checkbox"/> Smooth <input type="checkbox"/> Loamy <input type="checkbox"/>
Temperature: Ambient: 30C Track: N/A
Notes:

Tires:

Front Tires: Pro-Line Bow Tie
Front Compound: X2
Front Insert: Pro-Line Closed Cell
Rear Tires: Pro-Line Bow Tie
Rear Compound: X2
Rear Insert: Pro-Line Closed Cell
Wheel (F/R): #89297 Team Associated 83mm
Notes:

Body, Wings:

Body: JConcepts S3
Wings: #81106 Team Associated Kit
Wing Height: High: <input checked="" type="checkbox"/> Low: <input type="checkbox"/>
Gap to Tower: Stock Location
Weight:
Total Vehicle Weight: 3353g
Notes:

Vehicle Comments:

Notes: #81274 Upper Titanium Screw Kit; Kit engine mount
