

Front Suspension:

RESET
Ride Height: 38 mm (Body Off & Full Tank)

Camber: -1

Toe: +2* (Tierod Gap = 62.0 mm)

Anti-Roll Bar
Size: 2.4 mm (Green)

Gap: 2 mm

Ackerman
Notes: #81066 Steering Block

Arms

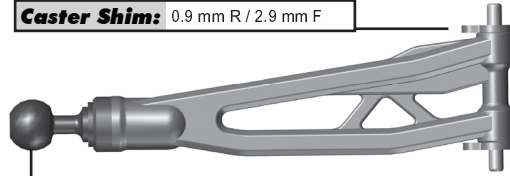

Drive Shaft: CVAs: Universals:
Chassis Brace: Short: Long:
Hex: #89095 FT Wheel Hexes

Notes: 1mm Removed From Front A-Arm; 2mm Shim Between Sway Bar Links; #81291 & #81292 HRC Arm Mounts (Center/Center); #81084 RC8B3.1 Servo Saver Tube & Spring

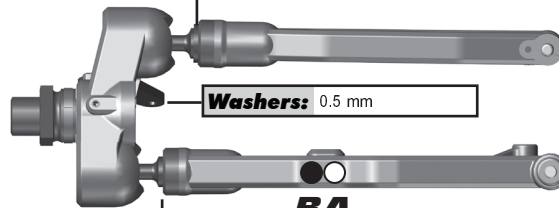
Caster Shim: 0.9 mm R / 2.9 mm F

Upper Ball Type: #81068 Aluminum

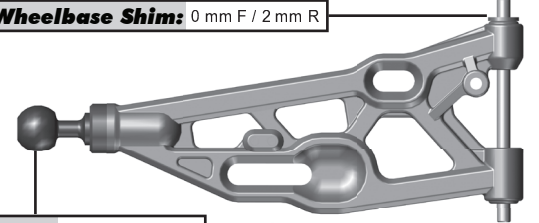
Upper Ball Shim: 0

Washers: 0.5 mm

BA
Lower Ball Shim: 0

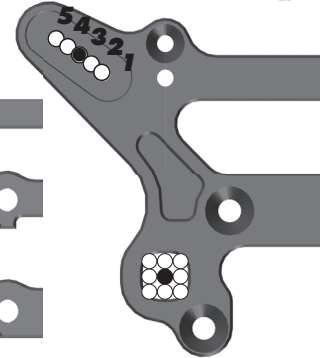
Wheelbase Shim: 0 mm F / 2 mm R

Lower Ball Type: #81068 Aluminum

Upper
Arm
Mount:

Arm
Mount B:

Rear Suspension:

Ride Height: 42 mm (Body Off & Full Tank)

Camber: -2*

Anti-Roll Bar
Size: 2.9 mm (Red)

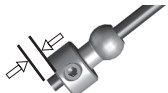
Gap: 0 mm

Drive Shaft: CVAs: Universals:
Chassis Brace: Short: Long:
Hex: #81319 Hex Drive, 17mm Offset

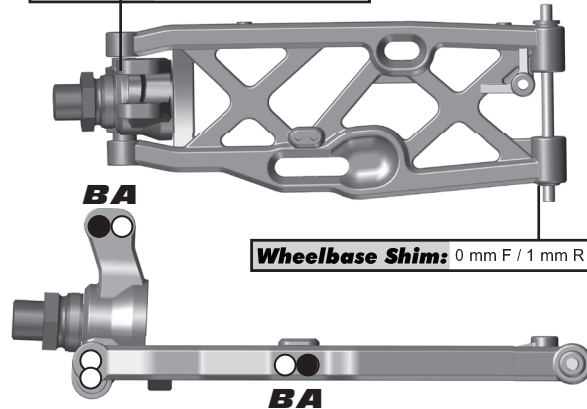
Notes: #81077 FT Aluminum Hubs (Middle); #81293 & #81294 HRC Arm Mounts (Center/Down); Sway Bar Link Moved 3mm Back In A-Arm

Hub Shim: 2.5 mm F / 2.5 mm R

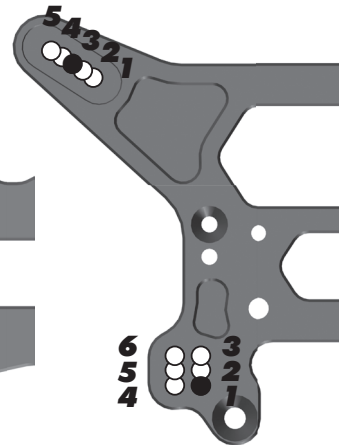
BA
Wheelbase Shim: 0 mm F / 1 mm R

BA
Arm
Mount C:

Arm
Mount D:

Electronics and Engine:

Radio: Sanwa M12S

Receiver Battery: Muchmore

Throttle Servo: Savox

Steering Servo: Savox

EPA: Throttle: N/A % Brake: N/A %

Brake Bias: 50% F / 50% R **D/R:** 100 %

Engine: Mx B2R **Temp:** N/A

Muffler: O.S. 2090SC **Fuel:** Mx 30%

Restrictor: 7.5mm **Glow Plug:** P3

Differential Fluid:

Front: 10,000

Center: 15,000 V3 / HTC / O O-Rings

Rear: 7,000

Notes:

Clutch and Gearing:

Spur Gear: 46 **Bell:** 13

Shoes: 3 x Aluminum

Springs: 2 x 1.0 + 2 x 1.1

Notes:

Shocks:

	Front	Rear
Piston:	8 x 1.3 Flat	8 x 1.3 Flat
Fluid:	50 wt	50 wt
Cap:	#81180 Bladder	#81180 Bladder
Rebound:	0	0
Spring:	Mugen 75/7.75T	HB Orange
Free Length:	109 mm	125.5 mm
Notes:	#81176 & #81177 Chrome Shock Shafts; #81407 Shock Seal Busing Set; #81164 & #81165 Fox Shock Bodies	

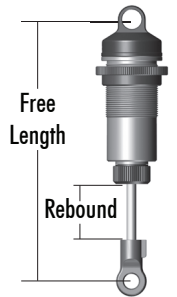

Track Info:

Size: Small Medium Large Extra Large
Surface: Dirt Carpet Astroturf Multi Surface
Traction: Low Medium High Very High
Moisture: Dry Damp Wet
Condition: Indoor Outdoor Dusty Hard Packed
 Bumpy Grooved Smooth Loamy
Temperature: Ambient: 70F - 90F Track: 75F - 95F

Notes:

Tires:

Front Tires: JConcepts Reflex

Front Compound: Green or Blue

Front Insert: JConcepts Dirt Tech

Rear Tires: JConcepts Reflex

Rear Compound: Green or Blue

Rear Insert: JConcepts Dirt Tech

Wheel (F/R): JConcepts Mono

Notes:

Body, Wings:

Body: JConcepts Finisher

Wings: #81006 Team Associated Kit

Wing Height: High: Low:
Gap to Tower: Stock Holes

Weight:

Total Vehicle Weight: 4010g

Notes:

Vehicle Comments:

Notes: #81274 Upper Titanium Screw Kit; #1363 FT Aluminum Servo Horn, 18.5 mm; #81085 Servo Saver Arm, Aluminum; #81115 Engine Mount; HRC Arm Mount Locations = 1 Location Lower Than Kit Arm Mounts